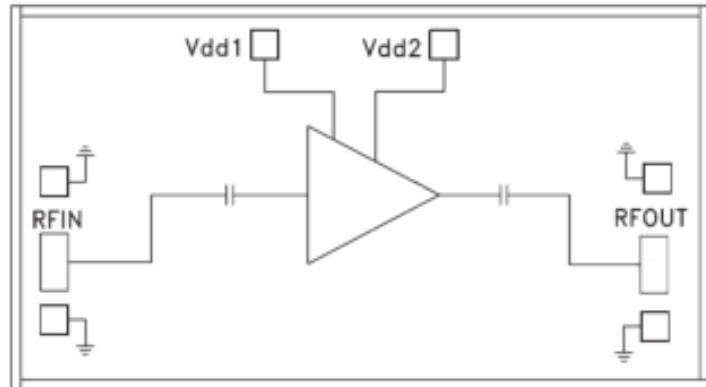

Features

- Frequency: 6-20GHz
- Small Signal Gain: 14.5dB
- Gain Flatness: $\leq \pm 1.5$ dB
- P1dB: 19.5dBm
- Psat: 20.5dBm
- Power Supply: +5V/110mA
- Input/Output: 50 Ω
- Die Size: 1.025 x 1.05 x 0.1 mm

Functional Block Diagram

Typical Applications

- Test Instrumentation
- Microwave Radio & VSAT
- Military & Space
- Telecom Infrastructure
- Fiber Optics

Electrical Specifications

TA = +25°C, Vd = +5V

Parameters	Min.	Typ.	Max.	Units
Frequency	6-20			GHz
Small Signal Gain	12	14.5	15.5	dB
Gain Flatness		± 1.5		dB
Output 1dB Compression (P1dB)	19	19.5	20	dBm
Saturated Output Power (Psat)	20	20.5	21	dBm
Input Return Loss	5	11		dB
Output Return Loss	8	17		dB
Static Current		110		mA



Gain vs. Frequency

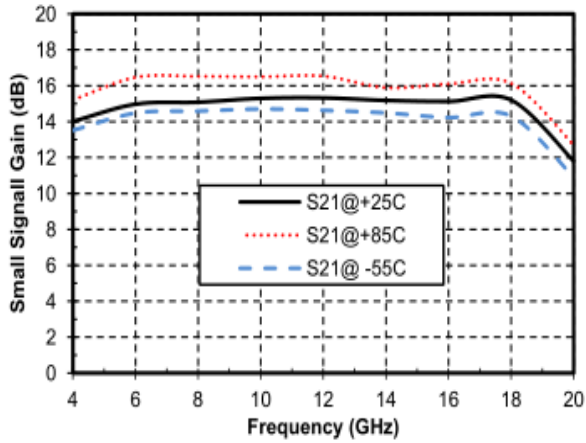

Reverse Isolation vs. Frequency

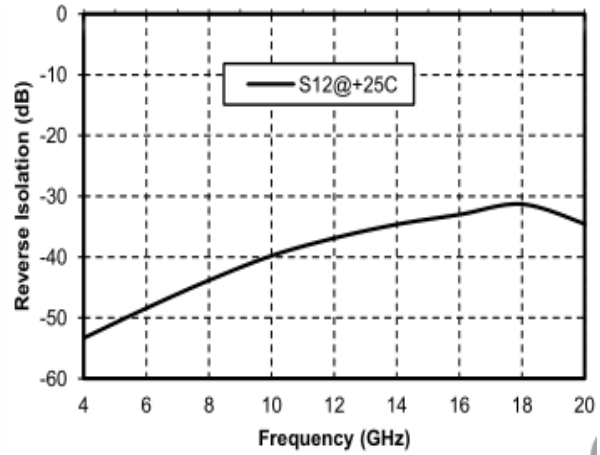

Input Return Loss vs. Frequency

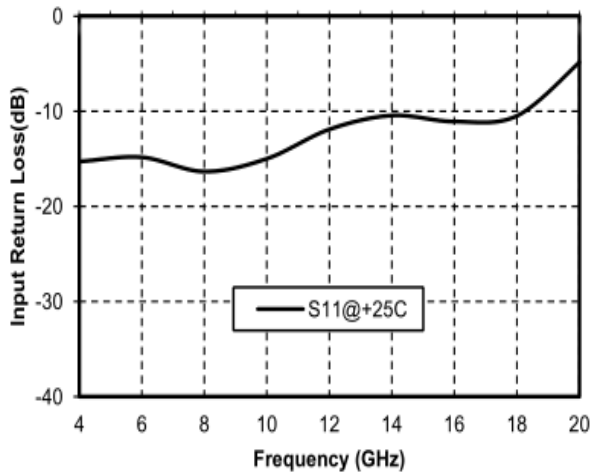

Output Return Loss vs. Frequency

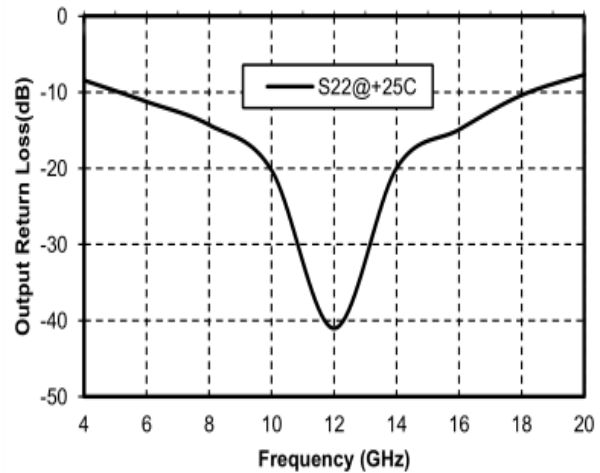



P-1dB vs. Frequency

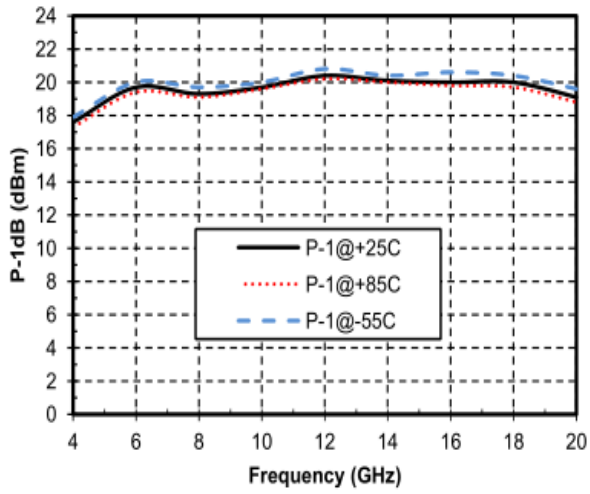

Psat vs. Frequency

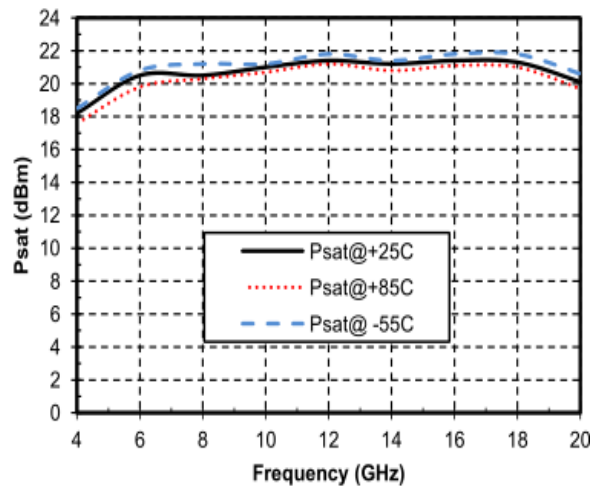



Outline Drawing:

All Dimensions in μm

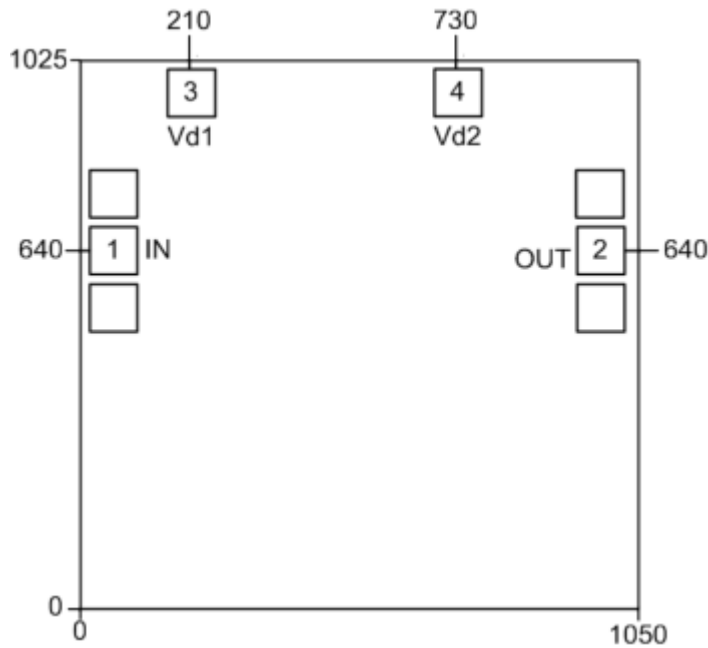

Pad Description

PAD	Function	Description	Equivalent circuit
1	RF IN	RF signal input terminal, no blocking capacitor required.	
2	RF OUT	RF signal output terminal, no blocking capacitor required.	
3, 4	Vd	Amplifier drain bias, connected to external 100pF bypass capacitor.	
Die Bottom	GND	Die bottom must be connected to RF/DC ground.	



Assembly Drawing

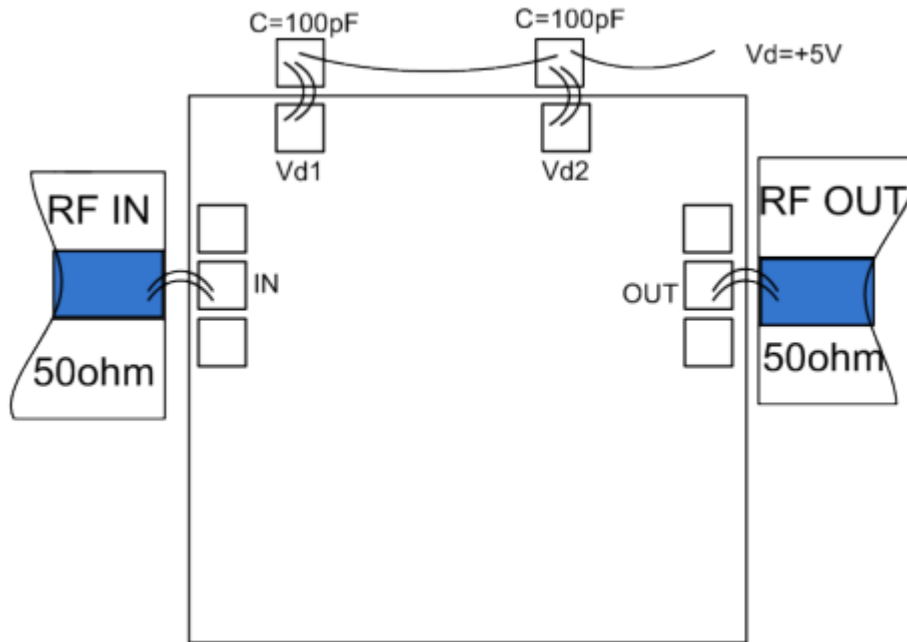

Notes:

1. Die thickness: 100um
2. Typical bond pad is 100*100 μm^2
3. Bond pad metalization: Gold
4. Backside metalization: Gold
5. Backside of the die (GND)
6. No connection required for unlabeled bond pads

Maximum Ratings:

1. Maximum drain voltage: +7V
2. Maximum input power: +20dBm
3. Operating temperature: -55°C to +85°C
4. Storage temperature: -65°C to +150°C