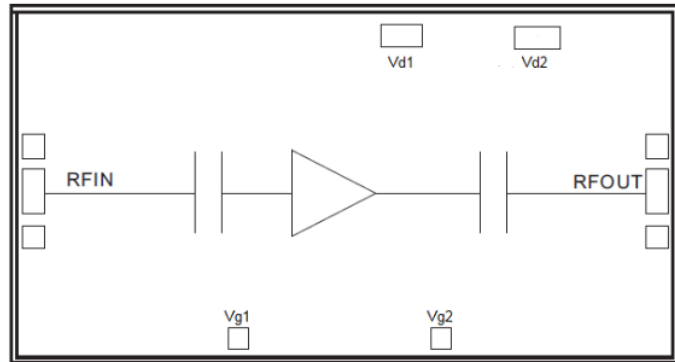

Features

- Frequency: 4-8GHz
- Small Signal Gain: 21dB
- Gain Flatness: ± 1.6 dB
- P1dB: 28.5dBm
- Psat: 29dBm
- Power Supply: 8V@190mA
- Input/Output: 50 Ω
- Die Size: 2.32 x 1.17 x 0.1 mm

Functional Block Diagram

Typical Applications

- Test Instrumentation
- Microwave Radio & VSAT
- Military & Space
- Telecom Infrastructure
- Fiber Optics

Electrical Specifications
TA = +25°C, Vd = +8V, Ids=190mA

Parameters	Min.	Typ.	Max.	Units
Frequency		4-8		GHz
Small Signal Gain		21		dB
Gain Flatness		± 1.6		dB
P1dB		28.5		dBm
Psat		29		dBm
Input Return Loss		18		dB
Output Return Loss		9		dB
Quiescent Current		190		mA
By tuning the Vg terminal voltage from -2V to 0V, the Vg terminal voltage is recommended to be -0.7V.				

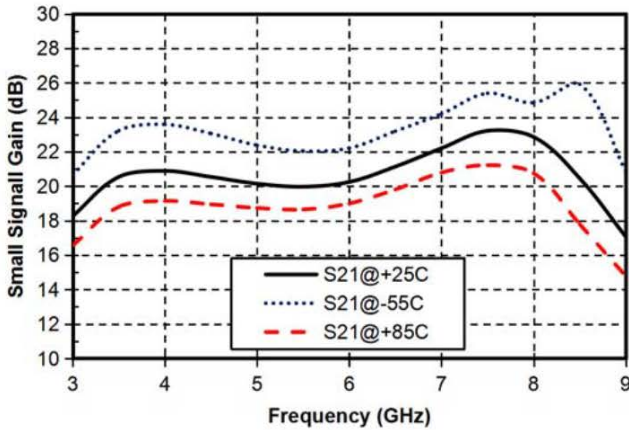
Gain vs. Frequency



Reverse Isolation vs. Frequency

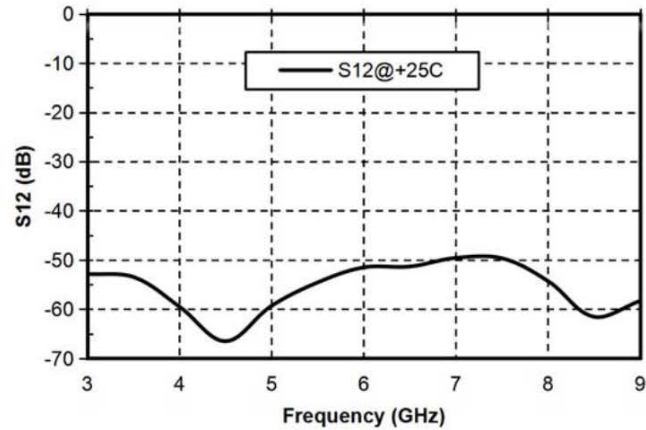

Input Return Loss vs. Frequency

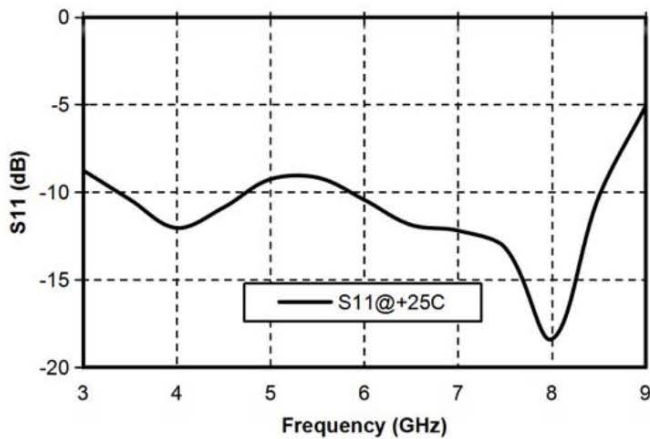

Output Return Loss vs. Frequency

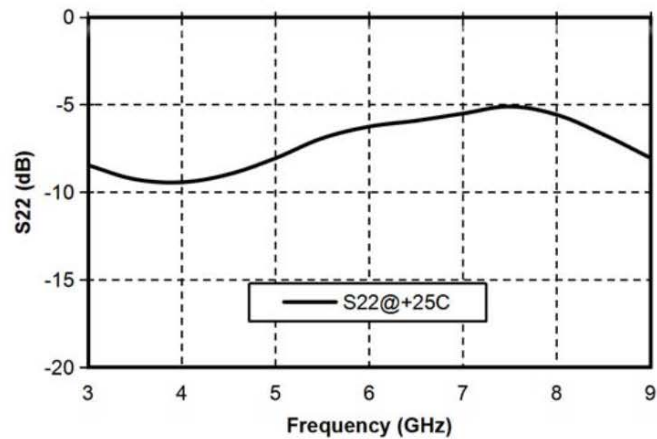

P-1dB vs. Frequency

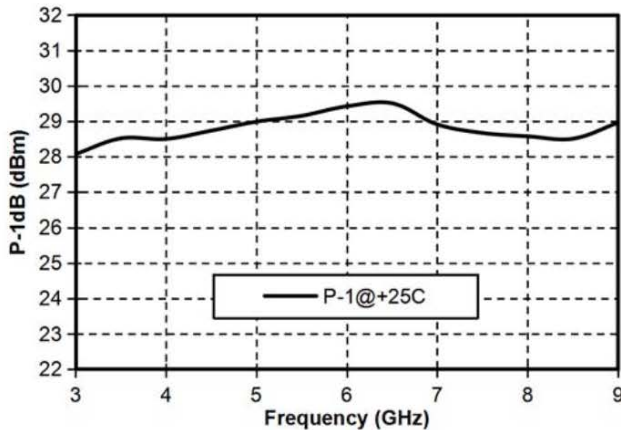

Psat vs. Frequency

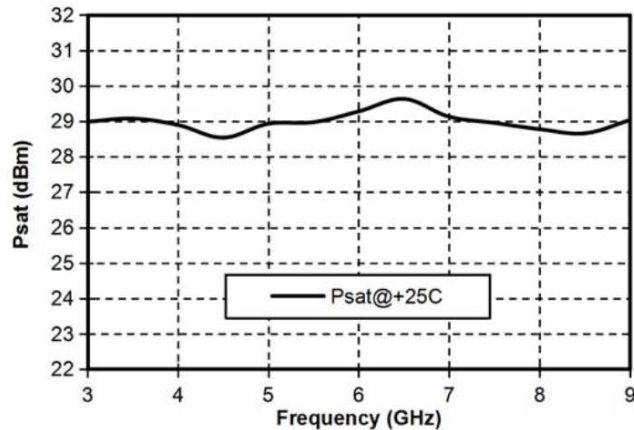



Outline Drawing: All Dimensions in μm

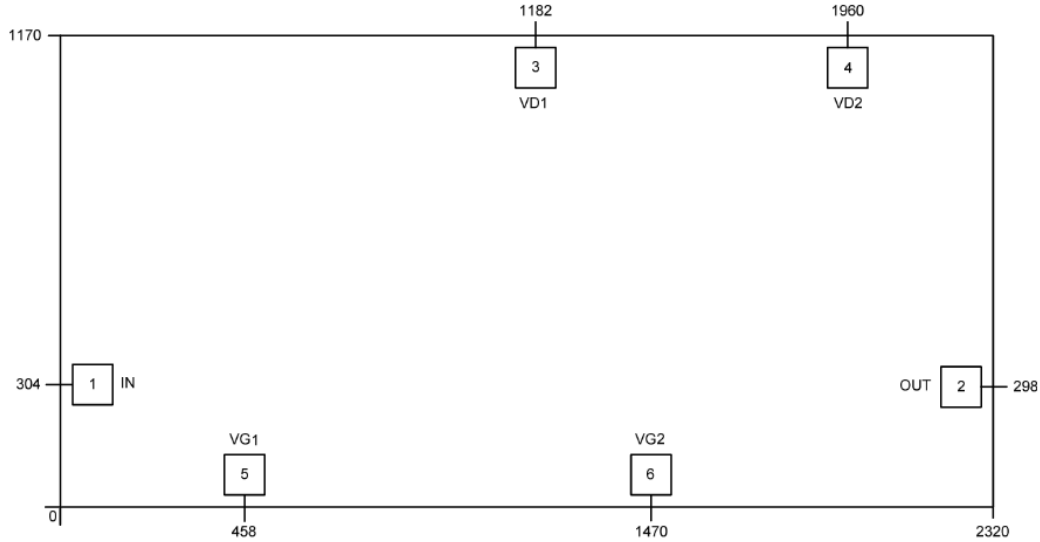

Pad Description

PAD	Function	Description
1	RF IN	RF signal input terminal, no blocking capacitor required
2	RF OUT	RF signal output terminal, no blocking capacitor required
3,4	Vd1, Vd2	Amplifier drain bias, connected to external 10pF, 1000pF, 3.3uF bypass capacitor.
5,6	Vg1, Vg2	Amplifier gate bias, connected to external 10pF, 1000pF 3.3uF bypass capacitor.
Die Bottom	GND	Die bottom must be connected to RF/DC ground



Assembly Drawing

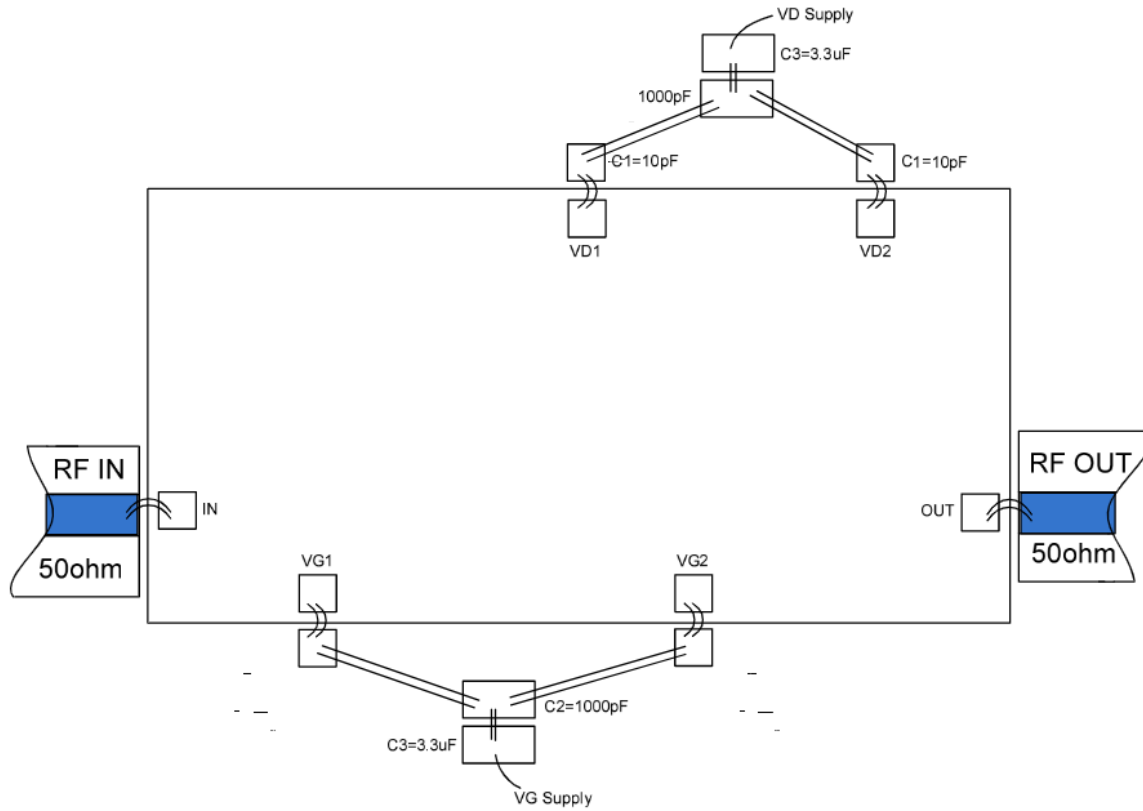

Notes:

1. Die thickness: 100um
2. Typical bond pad is 100*100 μm^2
3. Bond pad metalization: Gold
4. Backside metalization: Gold
5. Backside of the die (GND)
6. No connection required for unlabeled bond pads

Maximum Ratings:

1. Maximum drain voltage: +10V
2. Maximum input power: +20dBm
3. Operating temperature: -55°C to +85°C
4. Storage temperature: -65°C to +150°C