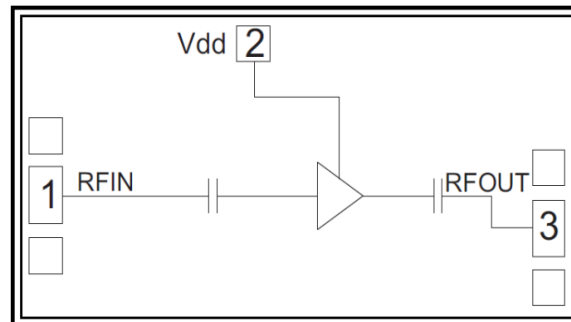

Features

- Single Biasing Voltage (Self Biased)
- Frequency: 1-12GHz
- Small Signal Gain: 17dB
- Noise Figure: 1.3dB typ.
- P1dB: 19dBm
- Power supply: +5V/40mA
- Input/Output: 50Ω
- Die Size: 1.6 x 1.25 x 0.09 mm

Functional Block Diagram

Typical Applications

- Test Instrumentation
- Microwave Radio & VSAT
- Military & Space
- Telecom Infrastructure
- Fiber Optics

Electrical Specifications
TA = +25°C, Vd = +5V

Parameters	Min.	Typ.	Max.	Units
Frequency	1-12			GHz
Small Signal Gain	16.5	17	18	dB
Gain Flatness		±0.75		dB
Noise Figure	-	1.3	1.7	dB
P1dB	18.5	19	19.5	dBm
Psat	19.5	20	21	dBm
Input Return Loss	11	13	-	dB
Output Return Loss	13	15	-	dB
Static Current		40		mA

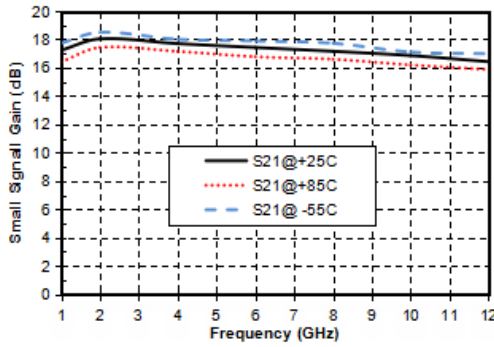
Gain vs. Frequency



Noise Figure vs. Frequency

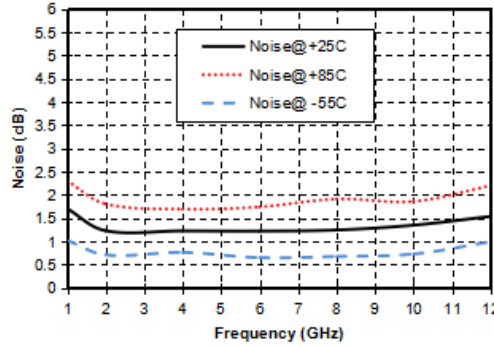

Input Return Loss vs. Frequency

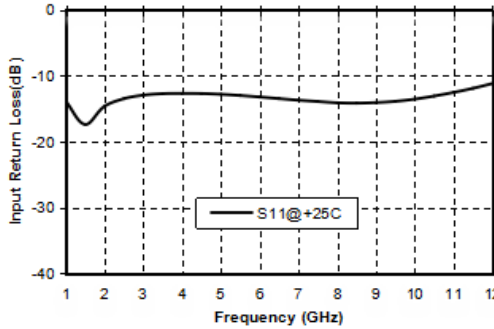

Output Return Loss vs. Frequency

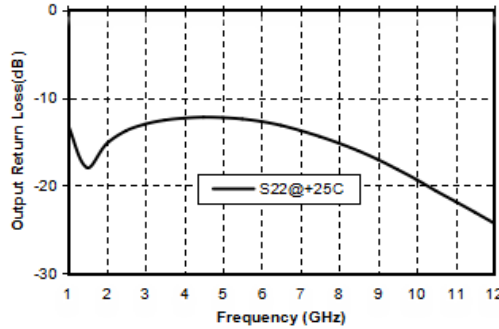

Reverse Isolation vs. Frequency

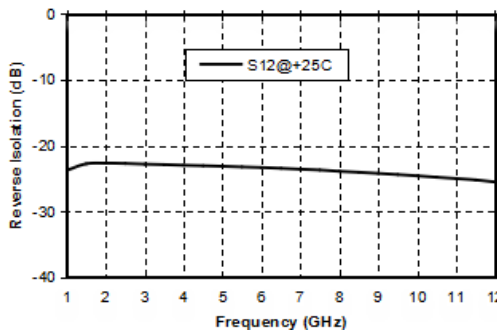

P1dB vs. Frequency

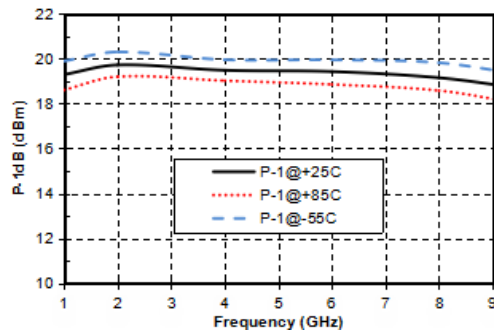



Outline Drawing:

All Dimensions in μm

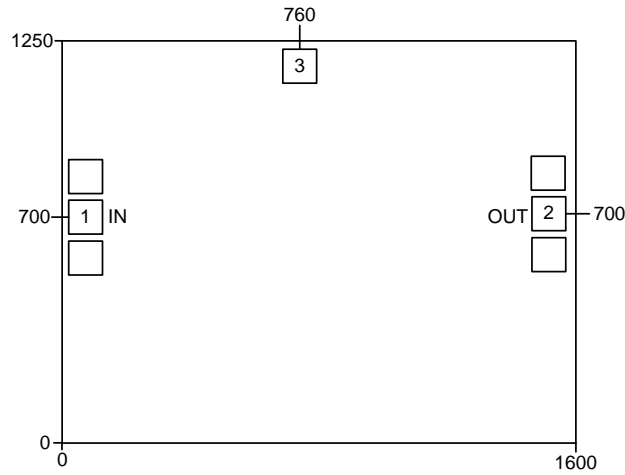

Pad Description

Pad	Function	Description
1	RF IN	RF signal input terminal, no blocking capacitor required.
2	RF OUT	RF signal output terminal, no blocking capacitor required.
3	VDD	Amplifier drain bias; external 100pF bypass capacitor required.
Die bottom	GND	Die bottom must be connected to RF/DC ground.



Assembly Drawing

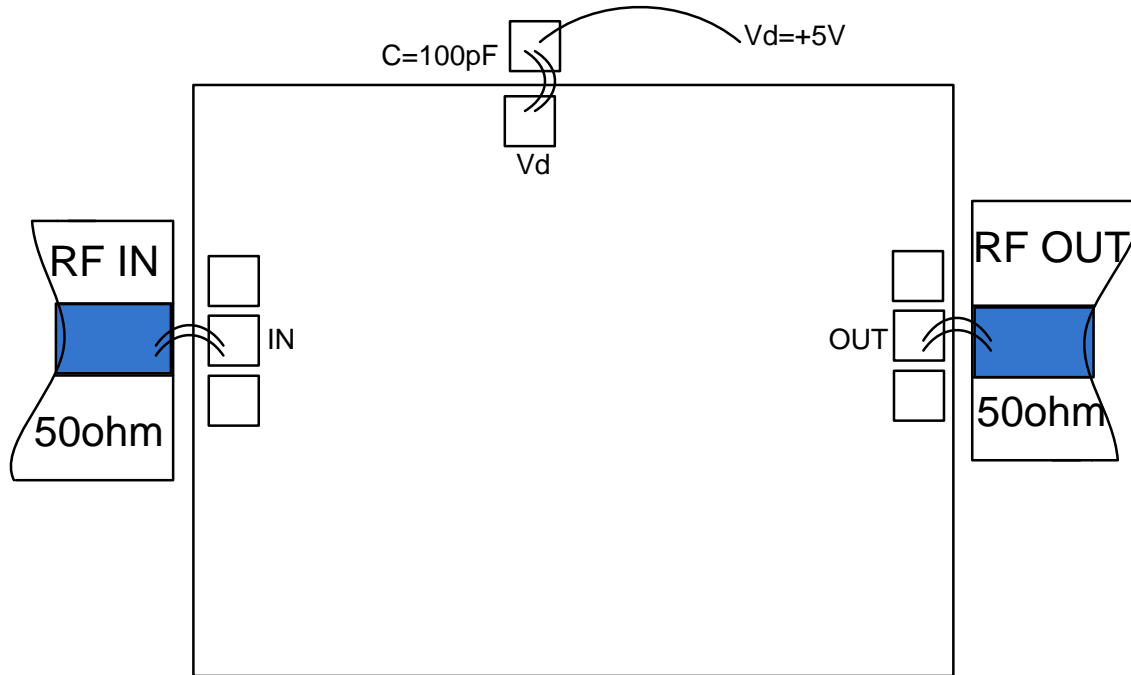

Notes:

1. Die thickness: 100um
2. Typical bond pad is 100*100 μm^2
3. Bond pad metalization: Gold
4. Backside metalization: Gold
5. Backside of the die (GND)
6. No connection required for unlabeled bond pads

Maximum Ratings:

1. Maximum drain voltage: +7V
2. Maximum input power: +10dBm
3. Operating temperature: -55°C to +85°C
4. Storage temperature: -65°C to +150°C