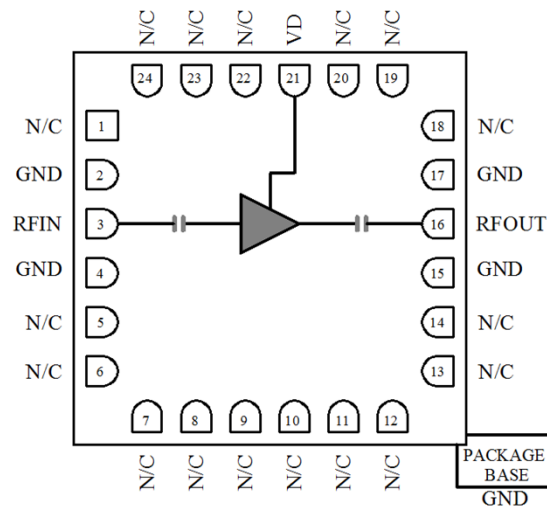

Features

- Single Biasing Voltage (Self Biased)
- Frequency: 0.5 - 4GHz
- Small Signal Gain: 32 Typical
- Gain Flatness: ± 0.5 dB Typical
- Noise Figure: 0.7 dB Typical
- P1dB: 19.5 dBm Typical
- Power Supply: +5V/65mA
- Input/Output: 50 Ω
- Package Size : 4 x 4x 0.8mm

Typical Applications

- Test Instrumentation
- Microwave Radio & VSAT
- Military & Space
- Telecom Infrastructure
- Fiber Optics

Functional Block Diagram

Electrical Specifications
TA = +25°C, VD = +5V, IDD = 65mA Typical

Parameters	Min.	Typ.	Max.	Units
Frequency	0.5		4	GHz
Small Signal Gain	30	32		dB
Gain Flatness		± 0.5		dB
Noise Figure		0.7		dB
P1dB - Output 1dB Compression	17	19.5		dBm
Past - Saturated Output Power		20		dBm
OIP3 - Output Third Order Intercept		30		dBm
Input Return Loss		12		dB
Output Return Loss		12		dB

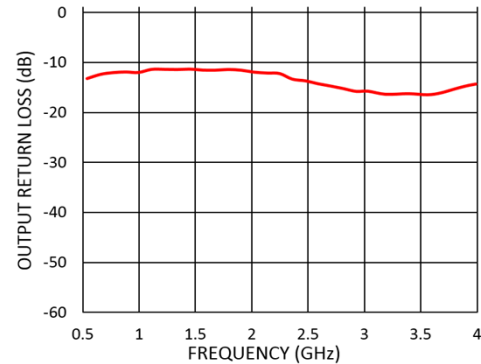
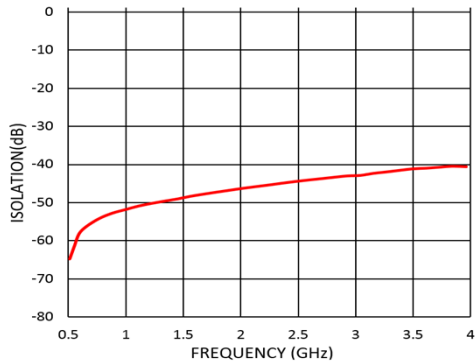
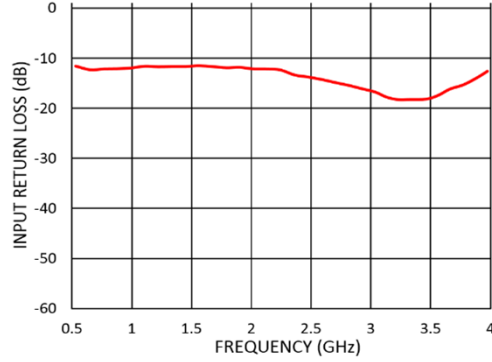
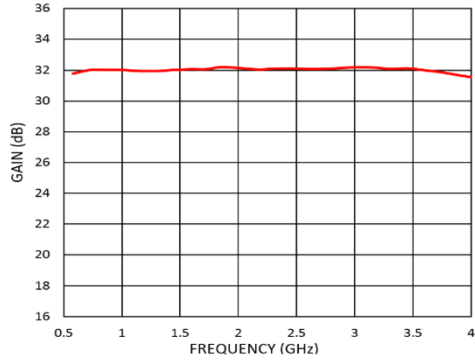

Measurement Plots: S-parameters



Measurement Plots: P1dB

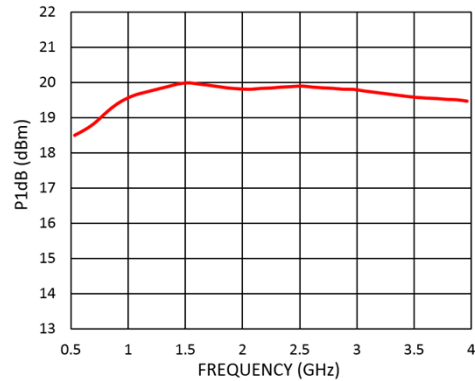

Measurement Plots: OIP3

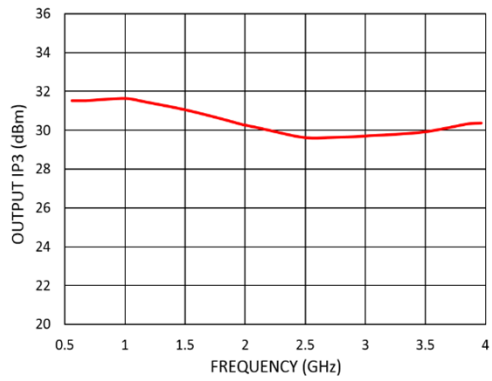

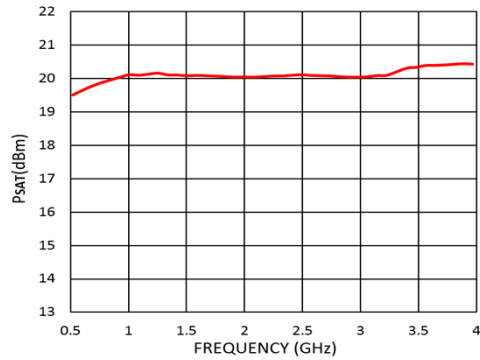
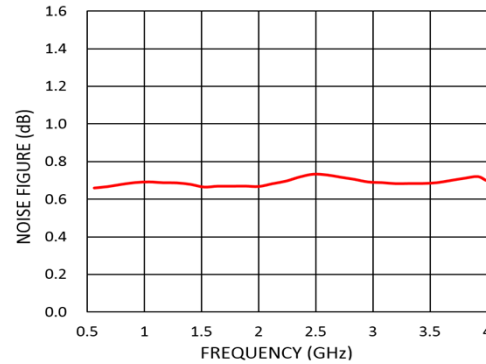
Measurement Plots: PSAT

Measurement Plots: Noise Figure

Absolute Maximum Ratings

Drain Bias Voltage (VD)	+6V
RF Input Power (RFIN)(VDD=+5V)	+18dBm
Channel Temperature	175°C
Continuous Pdiss (T = 85 °C) (derate 6mW/°C above 85 °C)	0.54W
Thermal Resistance (channel to die bottom)	50°C/W
Operating Temperature	-55°C to +85 °C
Storage Temperature	-55°C to +150 °C

Typical Supply Current vs. VD

VD (V)	IDD (mA)
+5	65



**ELECTROSTATIC SENSITIVE DEVICE
OBSERVE HANDLING PRECAUTIONS**



Outline Drawing: All Dimensions in mm[inches]

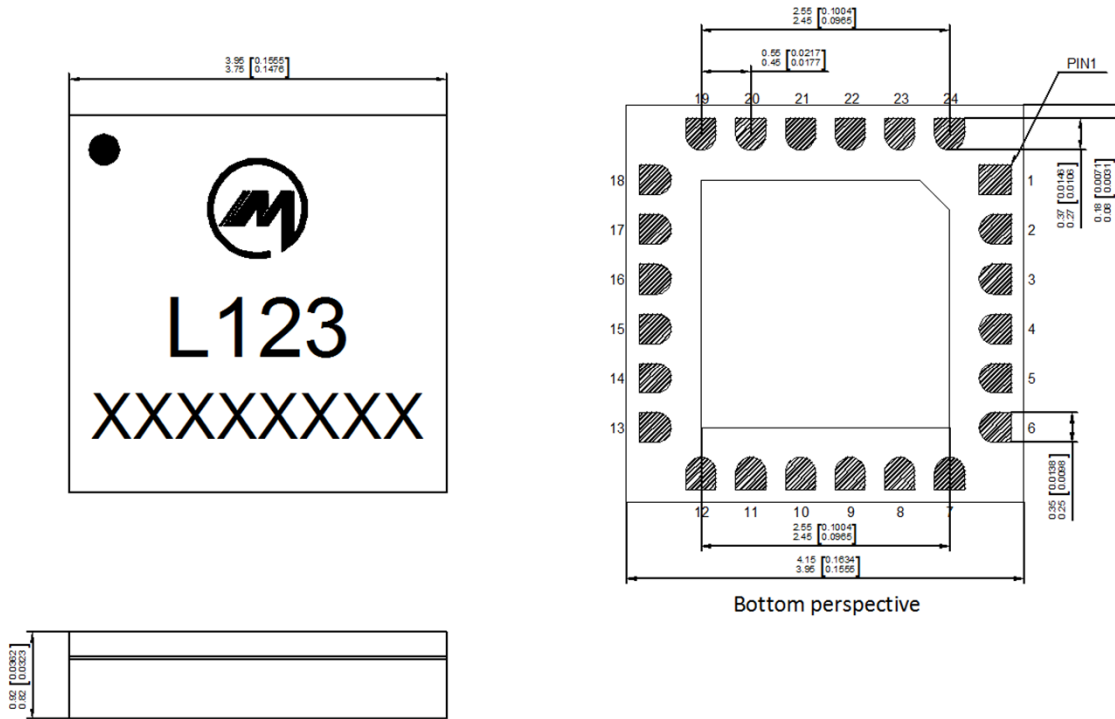

Notes:

1. Package body material : Alumina.
2. Lead and ground paddle plating: Gold flash over nickel.
3. Dimensions are in millimeters(inches).
4. Lead spacing tolerance is non-cumulative.



Assembly Drawing

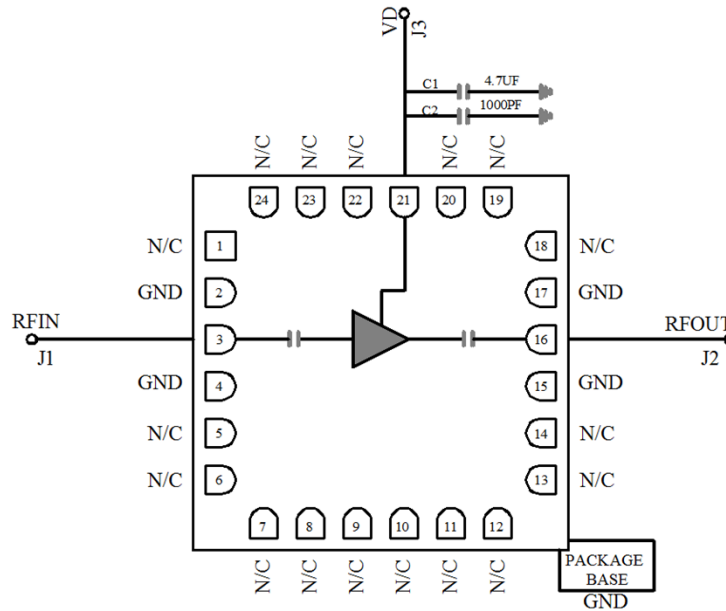

Pin Descriptions

No	Function	Description
1,5,6,7,8,9,10,11,12,13,14,18,19,20,22,23,24	NC	No connection. These pins may be connected to RF ground. Performance will not be affected.
3	RF IN	RF Signal Input. This pad is ac-coupled and matched to 50 Ω.
16	RF OUT	RF Signal Output. This pad is ac-coupled and matched to 50 Ω.
21	VD	Connect to external 1000pF and 4.7uF bypass capacitors.
2,4,15,17	GND	These pins & exposed ground paddle must be connected to RF/DC ground
	GND	Package bottom must be connected to RF/DC ground

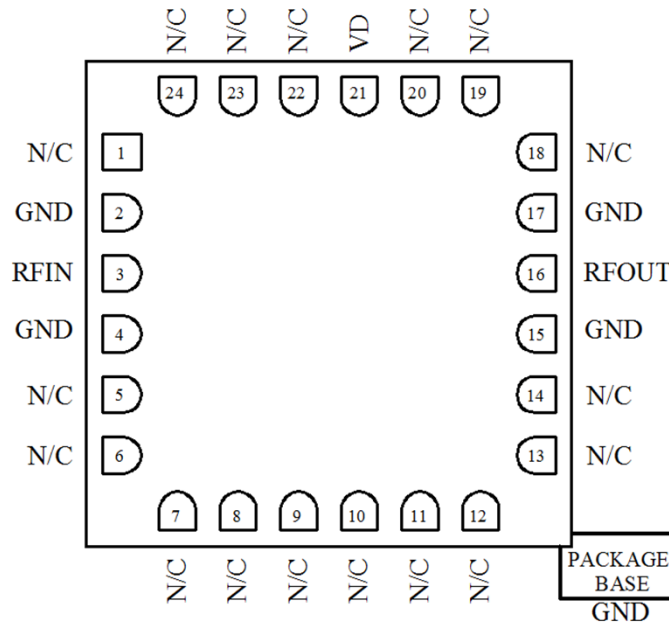

Biasing and Operation

Turn ON procedure:

1. Connect GND to RF and dc ground.
2. Apply positive drain voltage VD and set to +5.0 V .
3. Apply RF signal.

Turn OFF procedure:

1. Turn off the RF signal.
2. Turn off the positive drain voltage VD.

Miller MMIC Inc. All rights reserved

Miller MMIC, Inc. holds exclusive rights to the information presented in its Data Sheet and any accompanying materials. As a premier supplier of cutting-edge RF solutions, Miller MMIC has made this information easily accessible to its clients.

Although Miller MMIC believes the information provided in its Data Sheet to be trustworthy, the company does not offer any guarantees as to its accuracy. Therefore, Miller MMIC bears no responsibility for the use of this information. It is worth mentioning that the information within the Data Sheet may be altered without prior notification.

Customers are encouraged to obtain and verify the most recent and pertinent information before placing any orders for Miller MMIC products. The information in the Data Sheet does not confer, either explicitly or implicitly, any rights or licenses with regards to patents or other forms of intellectual property to any third party.

The information provided in the Data Sheet, or its utilization, does not bestow any patent rights, licenses, or other forms of intellectual property rights to any individual or entity, whether in regards to the information itself or anything described by such information. Furthermore, Miller MMIC products are not intended for use as critical components in applications where failure could result in severe injury or death, such as medical or life-saving equipment, or life-sustaining applications, or in any situation where failure could cause serious personal injury or death.