

Features

- Frequency: 6-18GHz
- Small Signal Gain: 26dB@+5V, 25dB@+6V
- P-1dB: 30.5dBm@+5V, 32dBm@+6V
- Psat: 31dBm@+5V, 32.5dBm@+6V
- Power Supply: +5V@1100mA, +6V@1100mA
- Input/Output: 50Ω
- Die Size: 3.3 x 2.4 x 0.1 mm

Functional Block Diagram

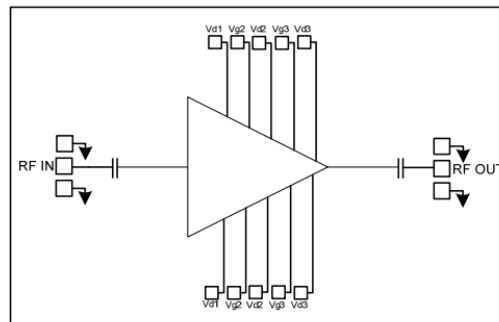

Typical Applications

- Test Instrumentation
- Microwave Radio & VSAT
- Military & Space
- Telecom Infrastructure
- Fiber Optics

Electrical Specifications

TA = +25°C, Vd = +5V, Vg=-0.75V, Ids=1100mA

Parameters	Min.	Typ.	Max.	Units
Frequency	6-18			GHz
Small Signal Gain	-	26	-	dB
Gain Flatness	±1.3			dB
P-1dB	-	30.5	-	dBm
Psat	-	31	-	dBm
Input Return Loss	-	15	-	dB
Output Return Loss	-	20	-	dB

* Adjust VG (-2V-0V), Recommended gate voltage -0.75V.

Gain vs. Frequency

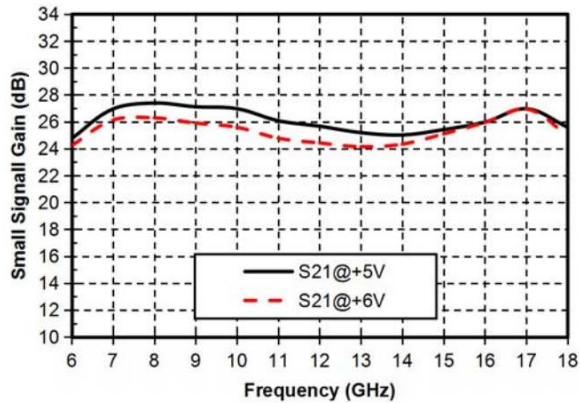

Isolation vs. Frequency

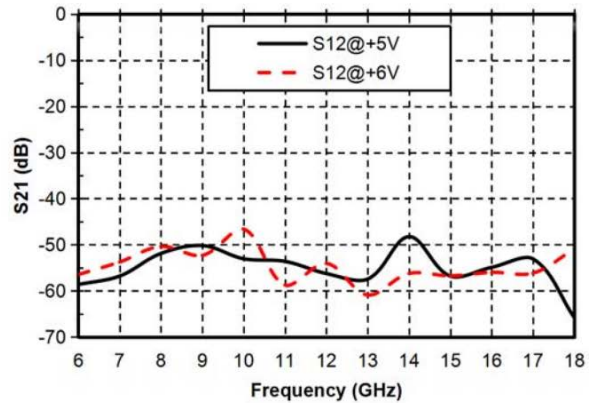

Input Return Loss vs. Frequency

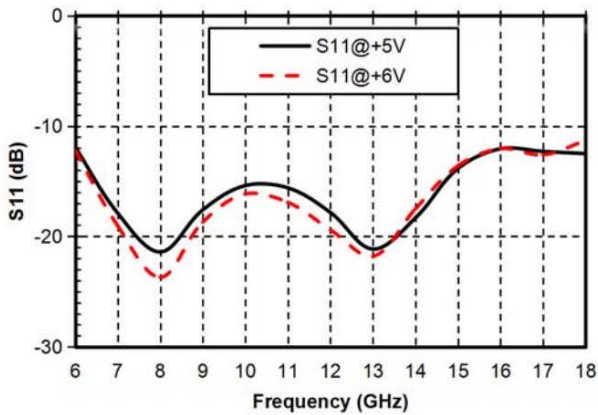

Output Return Loss vs. Frequency

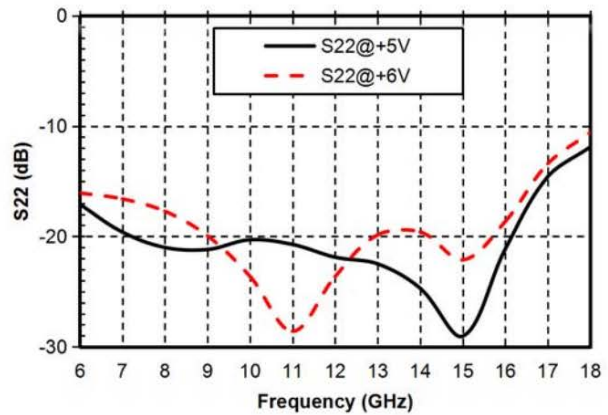

P-sat vs. Frequency

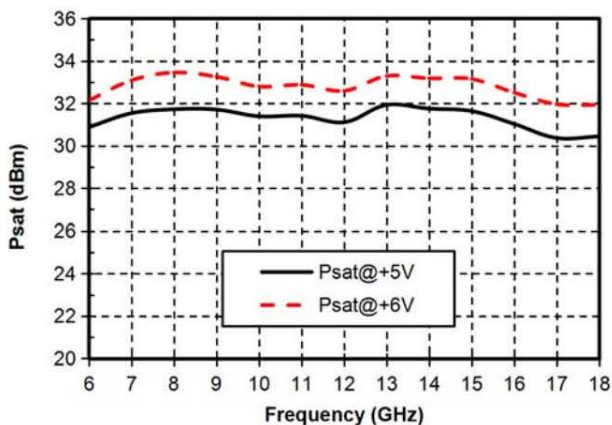

Idd vs. Frequency

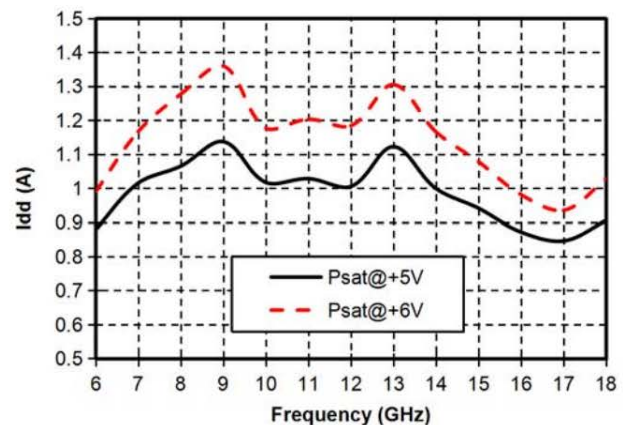



Outline Drawing: All Dimensions in μm

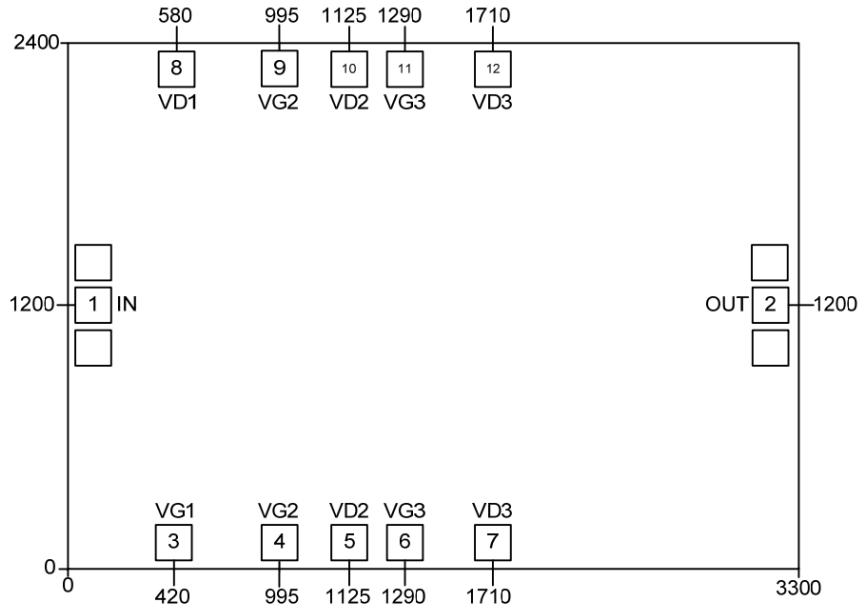

Pad Description

Pad	Function	Description
1	RF IN	Signal input terminal, connected to 50Ω circuit; no blocking capacitor required.
2	RF OUT	Signal output terminal, connected to 50Ω circuit; no blocking capacitor required.
5, 7, 8, 10, 12	VD1-3	Amplifier drain bias; external 100pF, 1000pF bypass capacitor required.
3, 4, 6, 9, 11	VG1-3	Amplifier gate bias; external 100pF, 1000pF bypass capacitor required.
Die bottom	GND	Die bottom must be connected to RF/DC ground.



Assembly Drawing

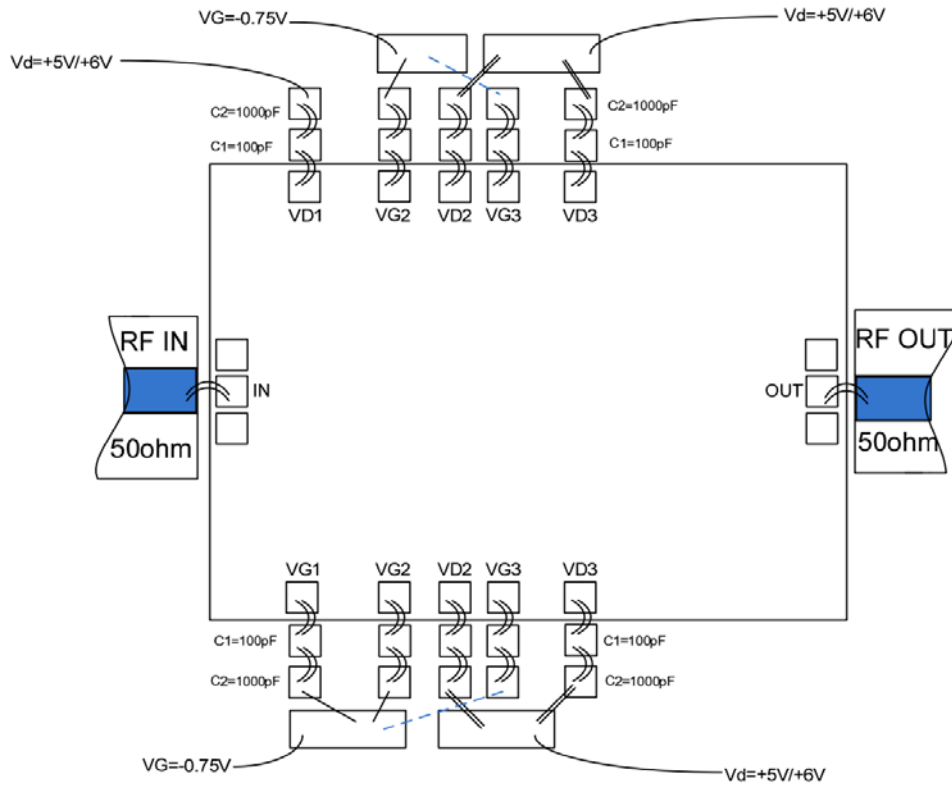

Note:
 C1 100pF
 C2 1000pF

Notes:

1. Die thickness: 100um
2. Typical bond pad is 100*100 μm^2
3. Bond pad metalization: Gold
4. Backside metalization: Gold
5. Backside of the die (GND)
6. No connection required for unlabeled bond pads

Maximum Ratings:

1. Maximum drain voltage: +9V
2. Maximum gate bias: -3V
3. Maximum input power: +25dBm
4. Operating temperature: -55°C to +85°C
5. Storage temperature: -65°C to +150°C