



Features

- Frequency: 13-15GHz
- Small Signal Gain: 28dB
- P-1dB: 32.5dBm
- Psat: 35dBm
- OIP3: 38dBm@14GHz
- Power Supply: +7V/560mA
- Input/Output: 50Ω
- Die Size: 2.82 x 1.62 x 0.1 mm

Typical Applications

- Test Instrumentation
- Microwave Radio & VSAT
- Military & Space
- Telecom Infrastructure
- Fiber Optics

Electrical Specifications

TA = +25°C, Vd = +7V, Ids=560mA

Parameters	Min.	Typ.	Max.	Units
Frequency	13-15			GHz
Small Signal Gain	-	28	-	dB
Gain Flatness	±0.25			dB
P-1dB	-	32.5	-	dBm
Psat	-	35	-	dBm
Input Return Loss	-	18	-	dB
Output Return Loss	-	12	-	dB

* Adjust VG (-2V-0V), Ids 560mA; Recommended gate voltage -1.0V.

Gain vs. Frequency

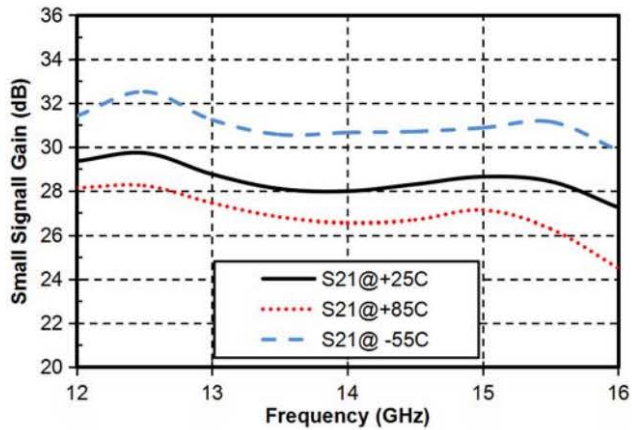

Isolation vs. Frequency

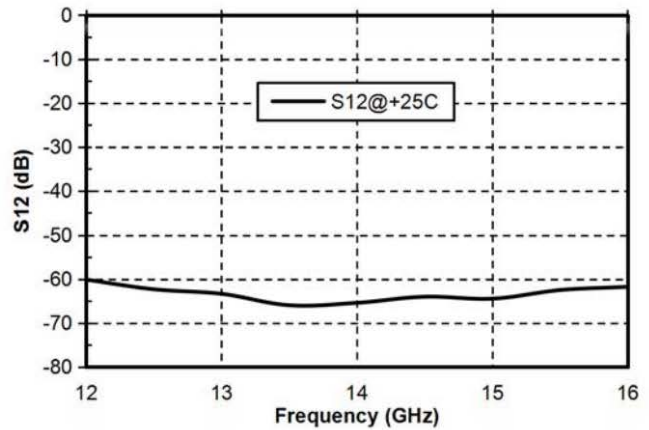

Input Return Loss vs. Frequency

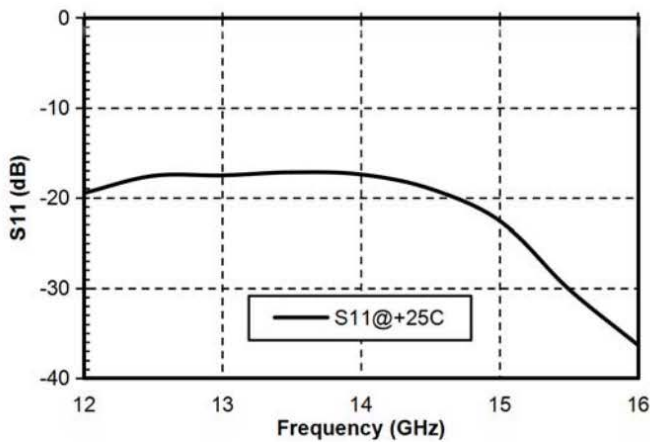

Output Return Loss vs. Frequency

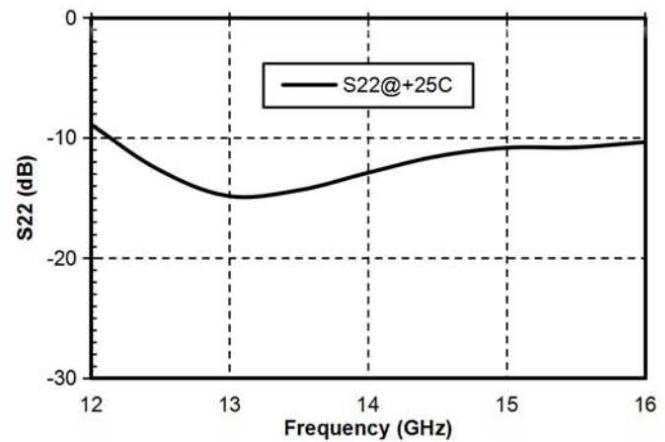

P-1dB vs. Frequency

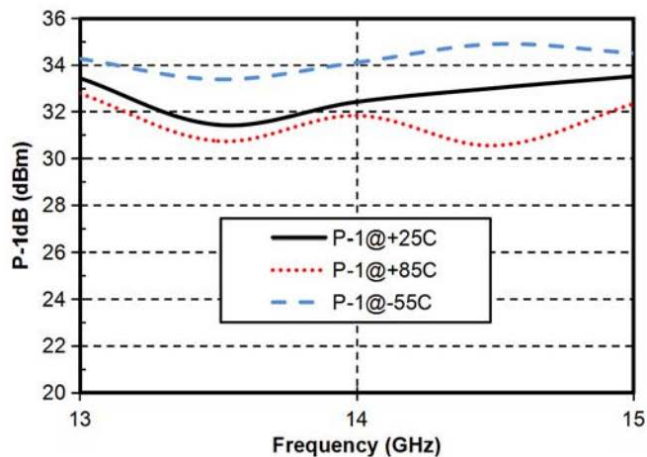

Psat vs. Frequency

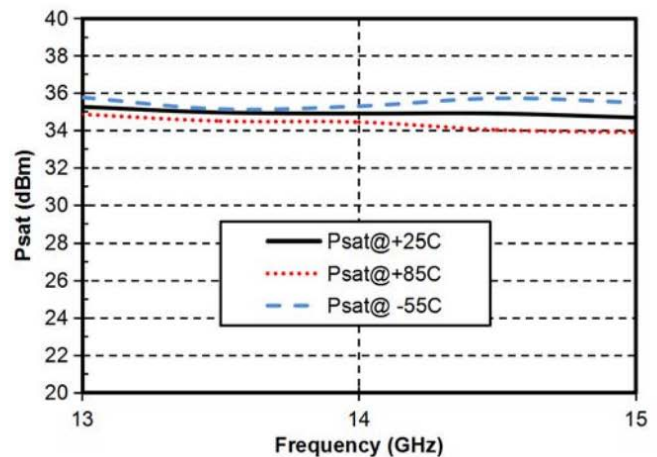



Outline Drawing: All Dimensions in μm

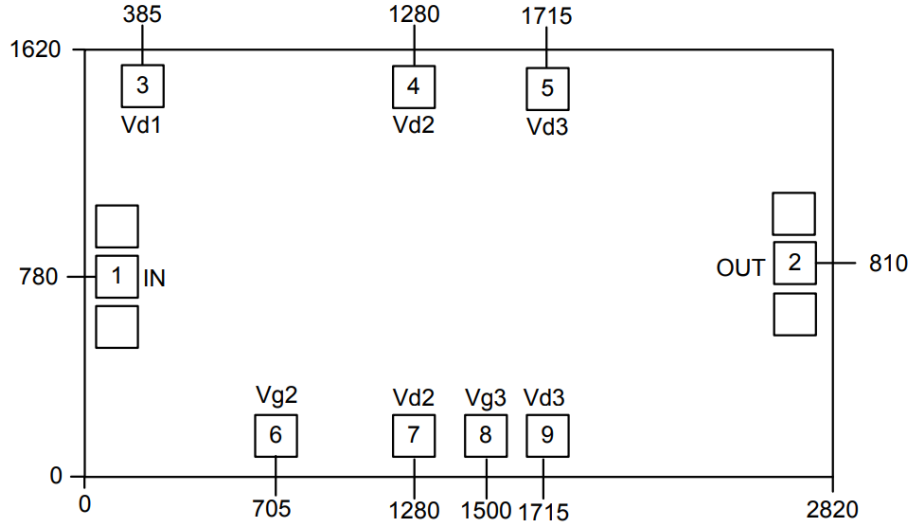

Pad Description

Pad	Function	Description
1	RF IN	Signal input terminal, connected to 50 Ω circuit ; no blocking capacitor required.
2	RF OUT	Signal output terminal, connected to 50 Ω circuit ; no blocking capacitor required.
3, 4, 5, 7, 9	Vd1~3	Amplifier drain bias; external 100pF, 1000pF, 4.7uF bypass capacitor required.
6, 8	Vg2, Vg3	Amplifier gate bias; external 100pF, 1000pF, 4.7uF bypass capacitor required.
Die bottom	GND	Die bottom must be connected to RF/DC ground.



Assembly Drawing

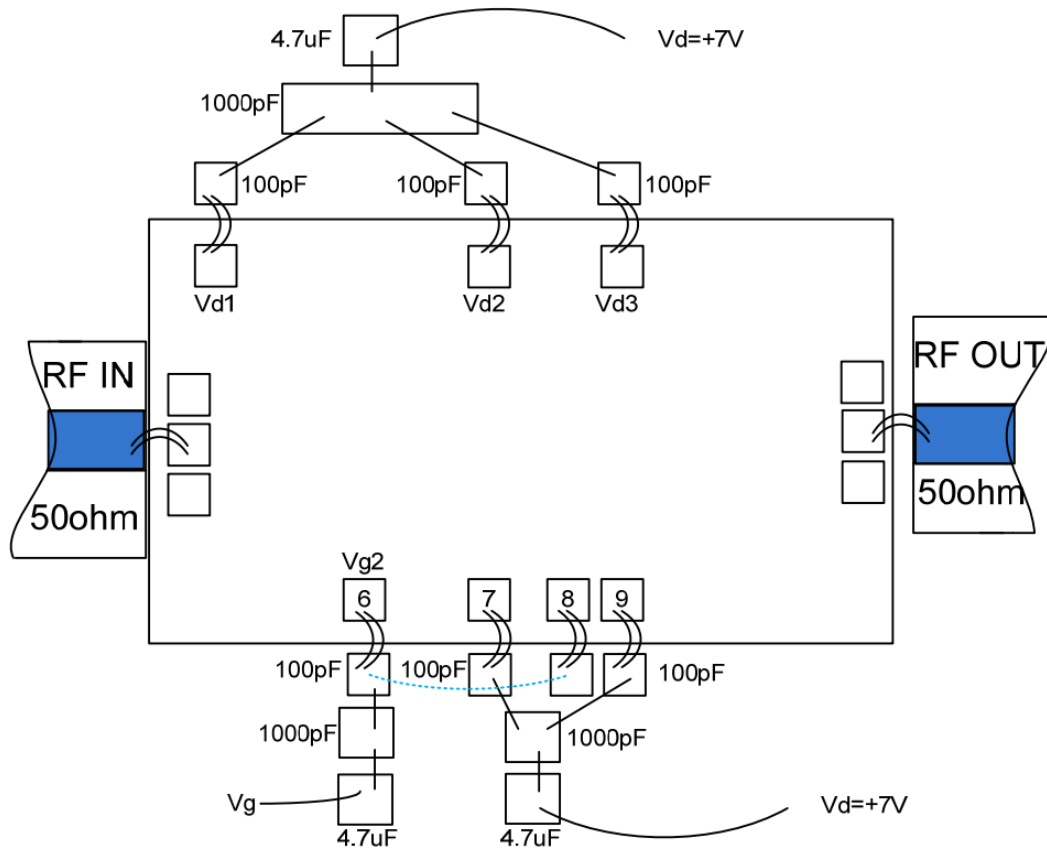

Notes:

1. Die thickness: 100um
2. Typical bond pad is 100*100 μm^2
3. Bond pad metalization: Gold
4. Backside metalization: Gold
5. Backside of the die (GND)
6. No connection required for unlabeled bond pads

Maximum Ratings:

1. Maximum drain voltage: +8V
2. Maximum gate bias: -3V
3. Maximum input power: +15dBm
4. Operating temperature: -55°C to +85°C
5. Storage temperature: -65°C to +150°C