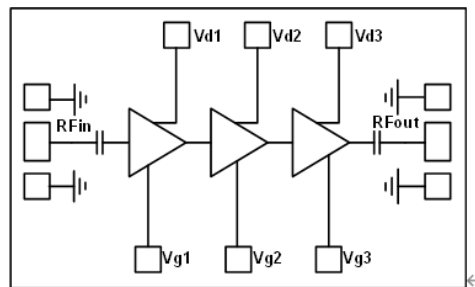

Features

- Frequency: 51-63GHz
- Output Power: 28dBm
- Reverse Isolation: 50dB
- Small Signal Gain: 20dB
- Operating Current: 410mA
- Die Size: 3.0 x 1.75 x 0.05 mm

Functional Block Diagram

Typical Applications

- Test Instrumentation
- Microwave Radio & VSAT
- Military & Space
- Telecom Infrastructure
- Fiber Optics

Electrical Specifications

TA = +25°C, VD = +4V, VG = -0.4V, Id=410mA (On-wafer Measurement Results)

Parameters	Min.	Typ.	Max.	Units
Frequency	51-63			GHz
Small Signal Gain		20		dB
Reverse Isolation		50		dB
Output Power		28		dBm
Input Return Loss		20		dB
Output Return Loss		15		dB
Operating Voltage		+4/-0.4		V
Operating Current		410		mA



Output Power vs. Frequency

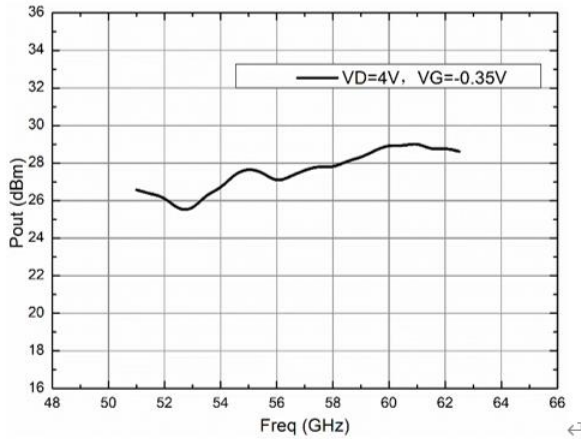

Gain vs. Frequency

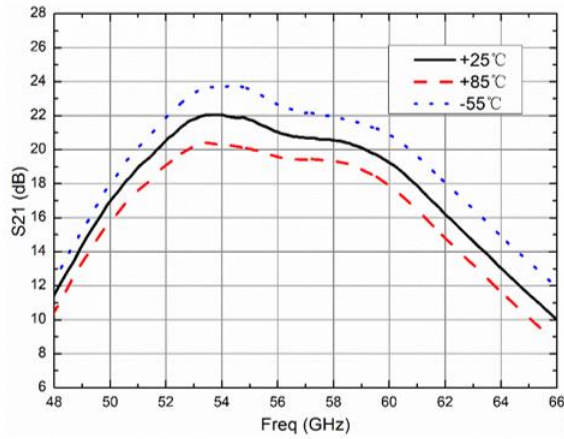

In-band VD vs. Frequency

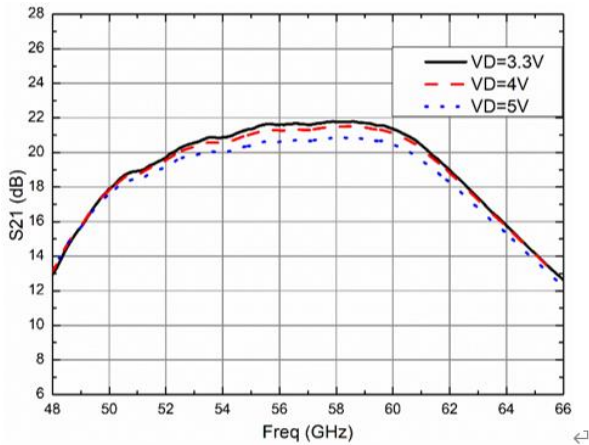

In-band VG vs. Frequency

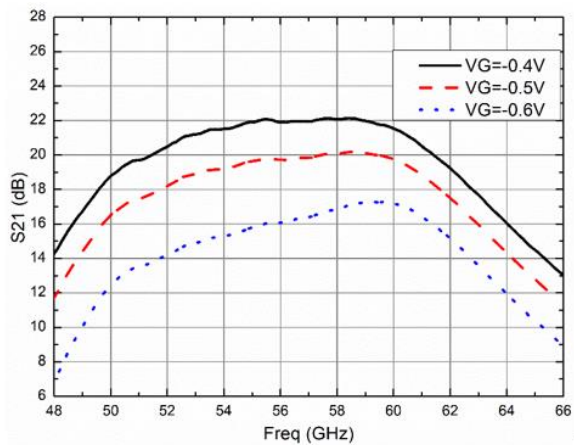

Input Return Loss vs. Frequency

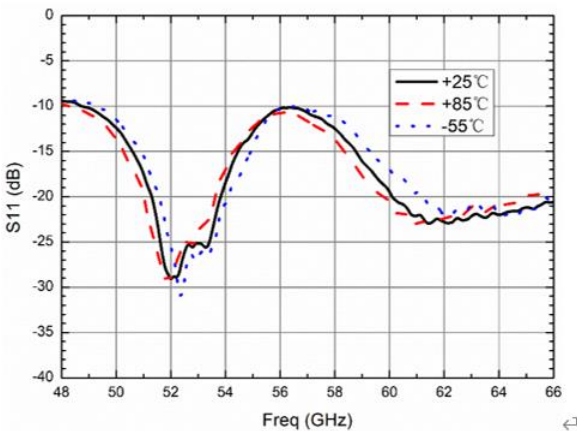

Output Return Loss vs. Frequency

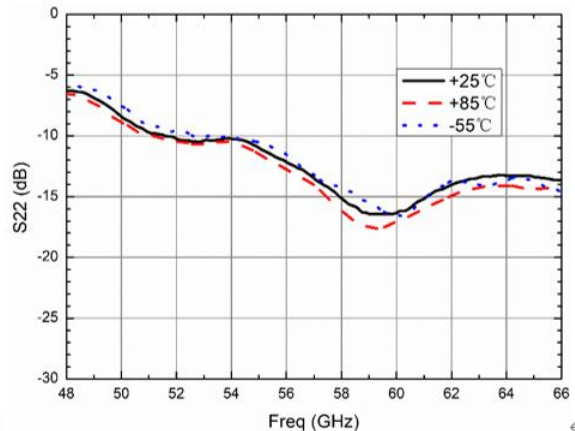



Reverse Isolation vs. Frequency

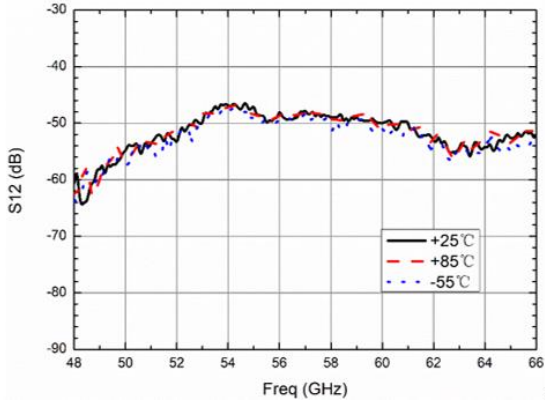

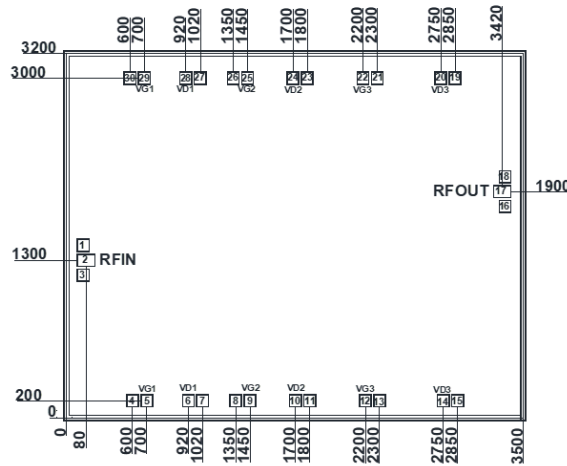

Outline Drawing:

All Dimensions in μm



Pad Description

Pad	Function	Description	Pad Size	Equivalent Circuit
2	RF IN	Signal input terminal	120 x 80	
17	RF OUT	Signal output terminal	120 x 80	
6,10,14,20,24,28	VD = 4V	Input drain power supply	80 x 80	

5,9,12,22,25,29	VG1/VG2/VG3	Output drain power supply	80 x 80	
1,3,4,7,8,11,13,15,16,18,19,21,23,26,27,30	GND	Grounded or suspended.	80 x 80	

Assembly Drawing (Bond testing)

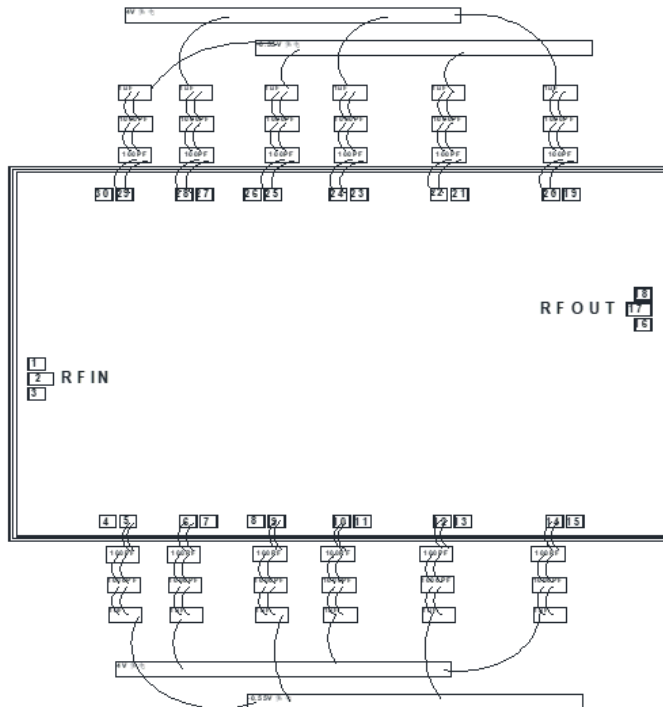

Notes:

1. Die thickness: 100um
2. Typical bond pad is 100*100 μm²
3. Bond pad metalization: Gold
4. Backside metalization: Gold
5. Backside of the die (GND)
6. No connection required for unlabeled bond pads

Maximum Ratings:

1. Maximum Supply voltage: +5.5V
2. Maximum input power: +22dBm
3. Operating temperature: -55°C to +85°C
4. Storage temperature: -65°C to +150°C