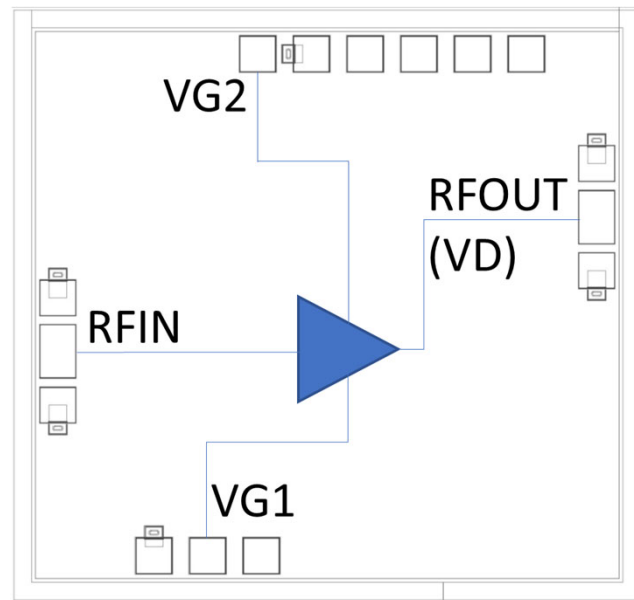

Features

- Frequency: DC-65GHz
- Small Signal Gain: >10 dB
- Gain Flatness: $\leq \pm 1.0$ dB@ DC-55GHz
- Noise Figure: 3.5 dB@35GHz
- P1dB = 19 dBm@35GHz
- Psat = 22.5 dBm@35GHz
- Power Supply: +8V/165mA
- Input/Output: 50 Ω
- Die Size: 1.6 x 1.7 x 0.05 mm

Typical Applications

- Test Instrumentation
- Microwave Radio & VSAT
- Military & Space
- Telecom Infrastructure
- Fiber Optics

Functional Block Diagram

Electrical Specifications

TA = +25°C, VD = +8V, VG1 = -0.4V, VG2 = 3.6V, ID = 165mA

Parameters	Min.	Typ.	Max.	Min.	Typ.	Max.	Min.	Typ.	Max.	Units
Frequency	DC-5			5-55			55-65			GHz
Small Signal Gain	15	16	17	13.5	14	14.5	10	12	14	dB
Gain Flatness		± 1.5			± 0.5			± 2		dB
Noise Figure	< 5.5			2.5	3	6	6		10	dB
Output 1dB Compression (P1dB)	20.5		21	16.5		20.5	13		16.5	dBm
Saturated Output Power (Psat)	24		24.5	20.5		24	19		20.5	dBm
Input Return Loss	< 7.7			< 5			< 4			dB
Output Return Loss	< 10			< 10			< 7			dB

* Adjust VG1, VG2 slightly to obtain device current of 165mA.



Outline Drawing:

All Dimensions in μm

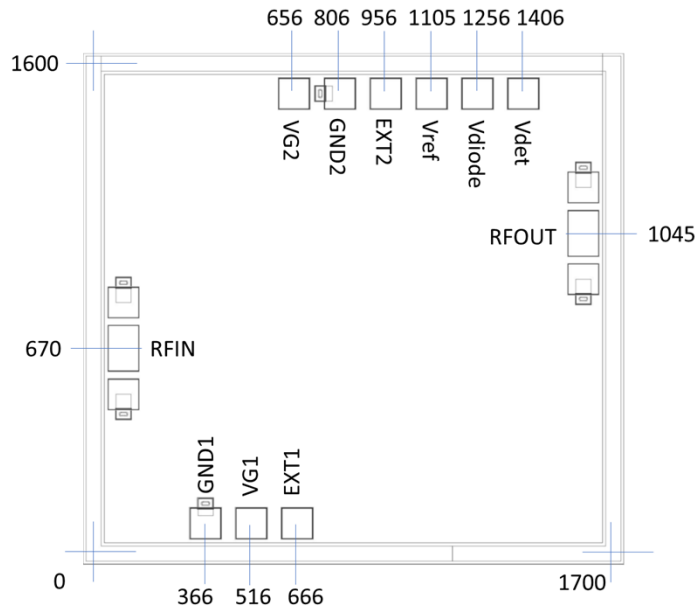

Pad Description

No	Function	Description
1	RF IN	Signal input terminal, connected to 50Ω circuit, DC-coupled
2	RF OUT	Signal output terminal, connected to 50Ω circuit; blocking capacitor required; external DC biasing network required.
3	VG1	Amplifier 1 st gate bias; connect to external 1000pF and 0.01uF bypass capacitors.
4	VG2	Amplifier 2 nd gate bias; connect to external 1000pF and 0.01uF bypass capacitors.
5	EXT1	External bypass pad; connect to external bypass capacitors.
6	EXT2	External bypass pad; connect to external bypass capacitors.
7	Vdiode	Diode biasing voltage
8	Vref	Reference diode output voltage
9	Vdet	Detector output voltage
10	GND1, GND2	Ground pads.



S-parameters and NF

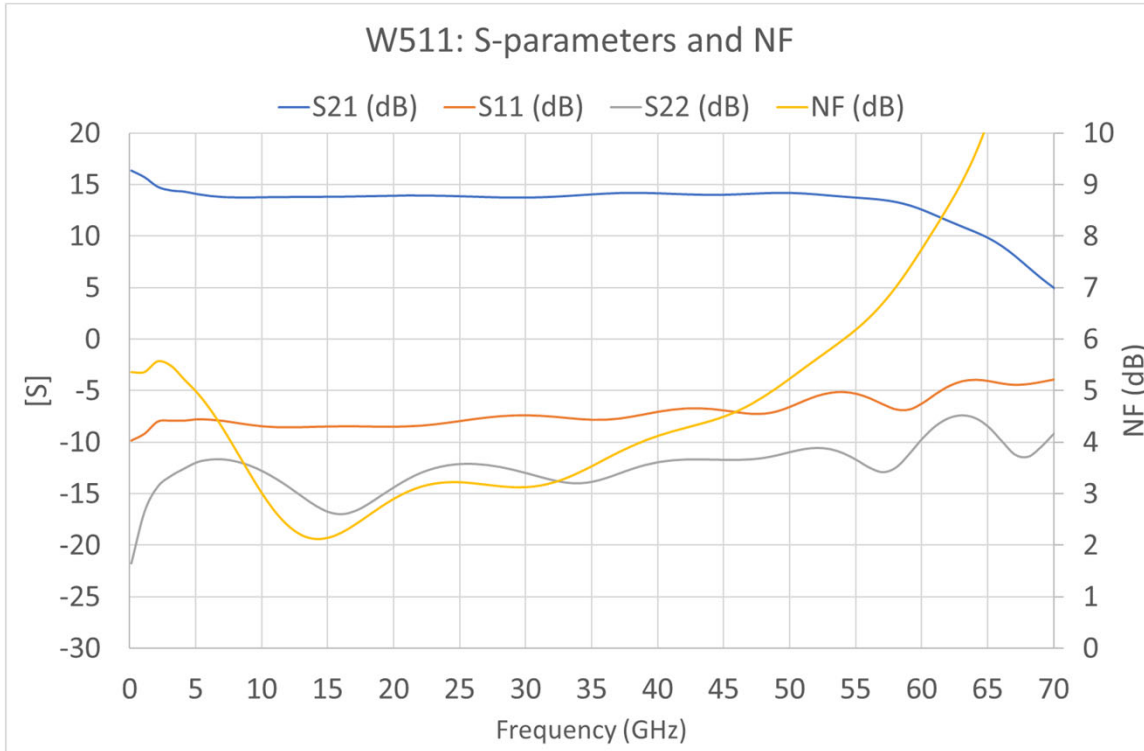

P1dB and Psat

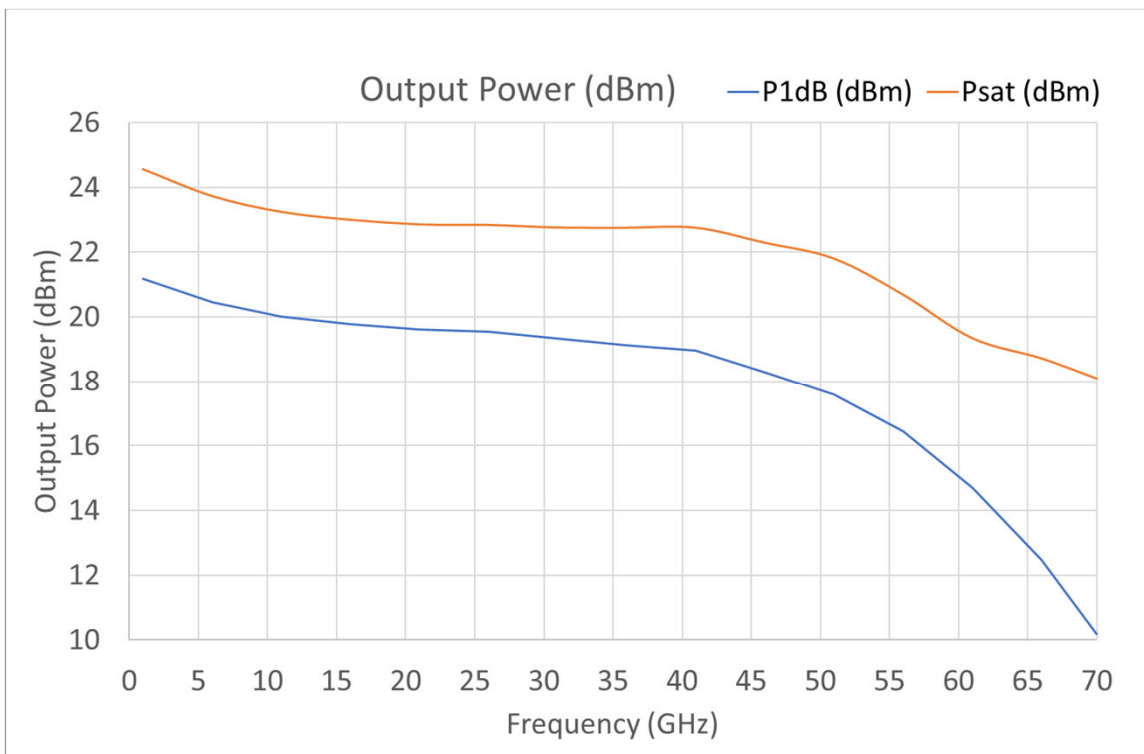



Power Detection: Vdet – Vref vs Pout at 40GHz, Vdiode = 1V

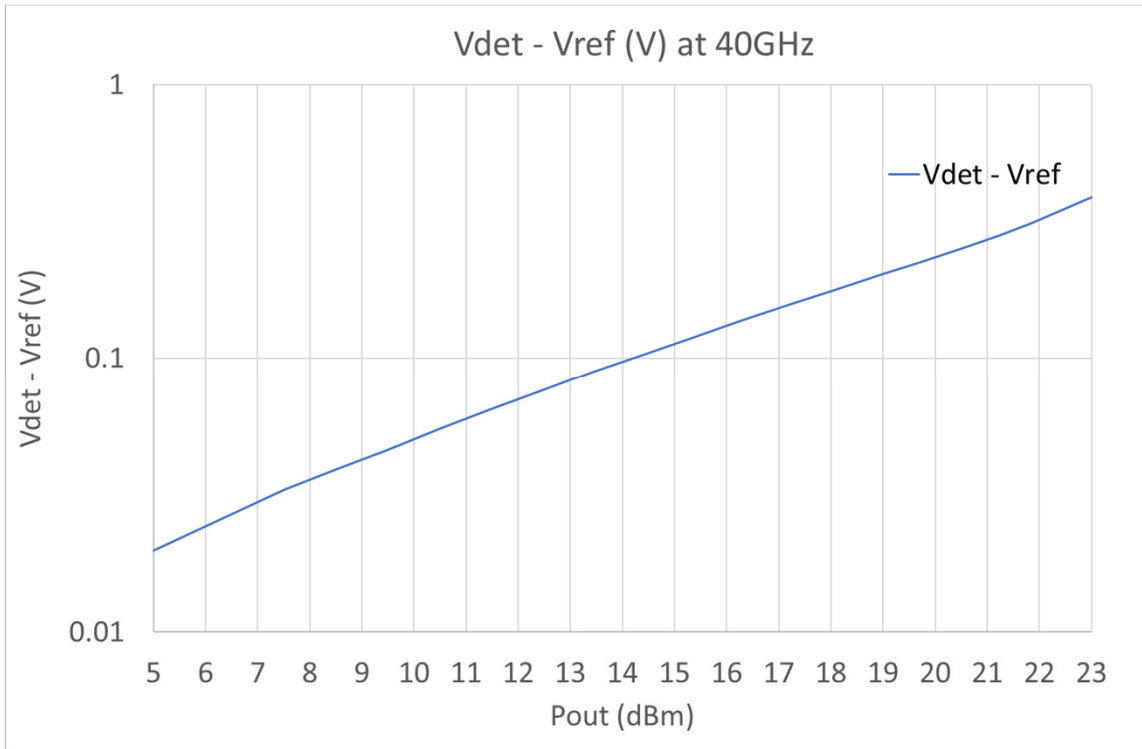

Power Detection: Vdet – Vref vs Frequency at P1dB, Vdiode = 1V

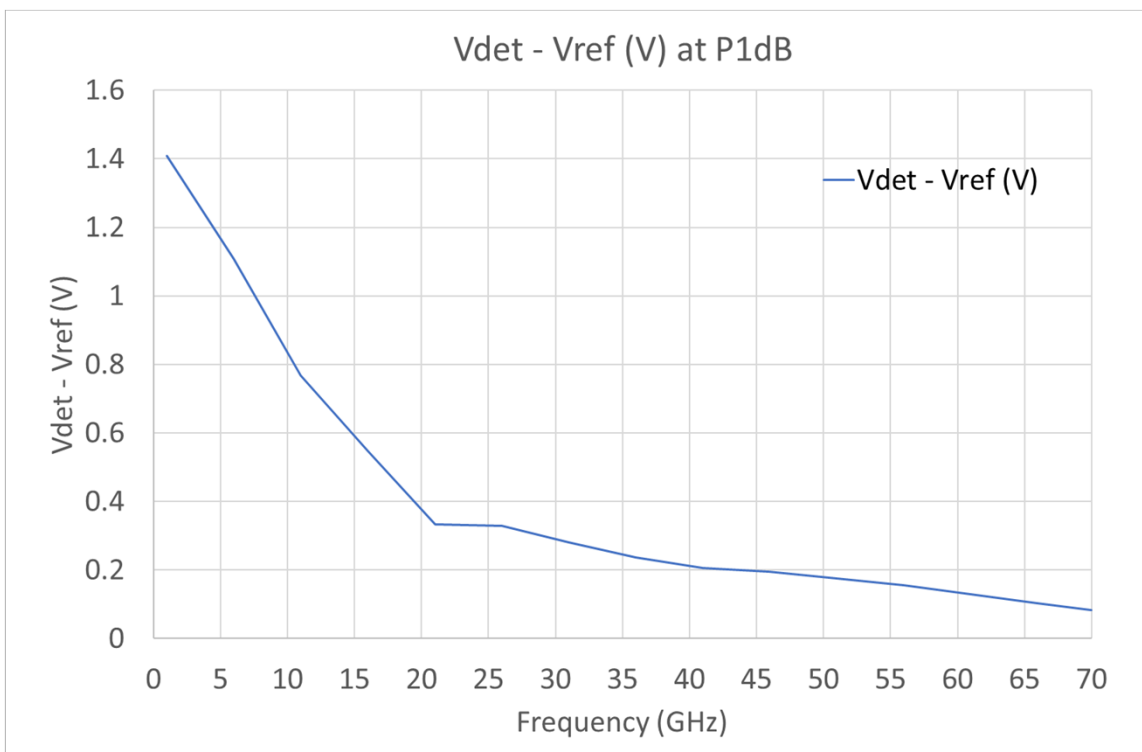



Assembly Drawing

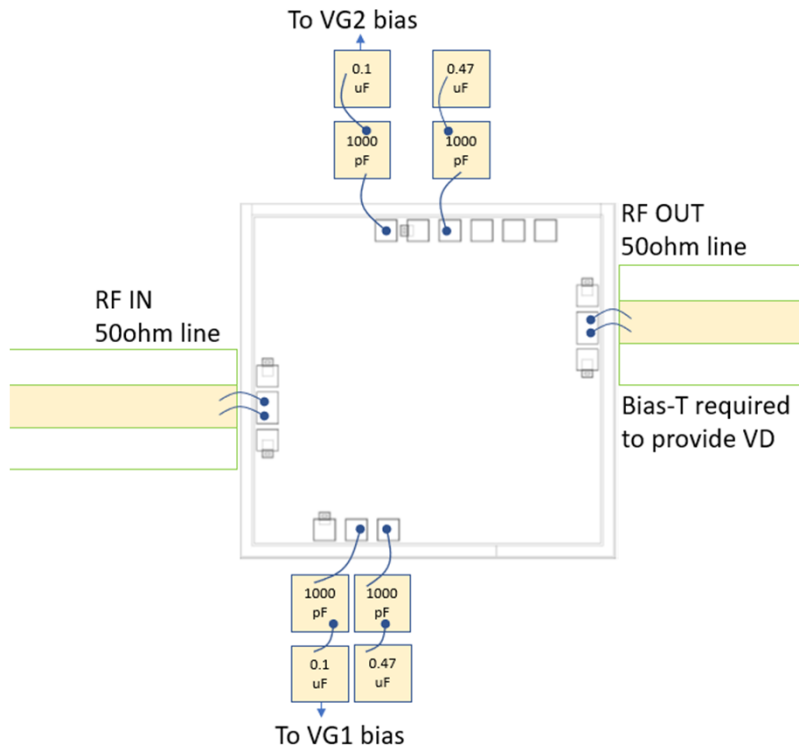

Notes:

1. Die thickness: 50um
2. DC bond pad is 100 x 100 μm^2
3. RF IN/OUT bond pad is 100 x 160 μm^2
4. Bond pad metalization: Gold
5. Backside metalization: Gold
6. Backside of the die (GND)