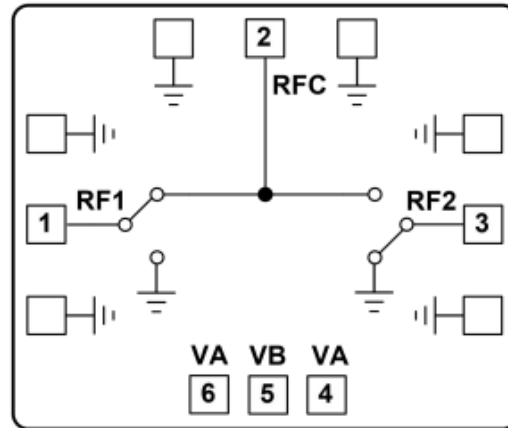

Features

- SPDT Reflective design
- Isolation: 38dB@2GHz
- Insertion Loss: 0.35dB@2GHz
- Input P-0.3: 47dBm@ 0.1GHz
- Input P-0.3: 42dBm@ 6GHz
- Switching Time: 30ns
- Input/Output: 50 Ohm matched
- Die Size: 2.00x1.00x 0.1 mm

Functional Block Diagram

Typical Applications

- TTL compatible driver included
- Fast Switching Speed
- Low Insertion Loss and High Isolation
- Customization available upon request

Electrical Specifications
TA = +25°C, VCTL=0/+28V

Parameters	Min.	Typ.	Max.	Units
Frequency		0.1-6		GHz
Insertion Loss@2GHz		0.35		dB
Insertion Loss@6GHz		0.8		dB
On-state Return Loss(RFC)		15		dB
On-state Return Loss(RF1/RF2)		15		dB
Off-state Return Loss		2		dB
Off-state Isolation		38		dB
Input power 0.3dB Compression@0.1GHz		47		dBm
Input power 0.3dB Compression@6GHz		42		dBm
Switching Time		30		ns



Insertion Loss

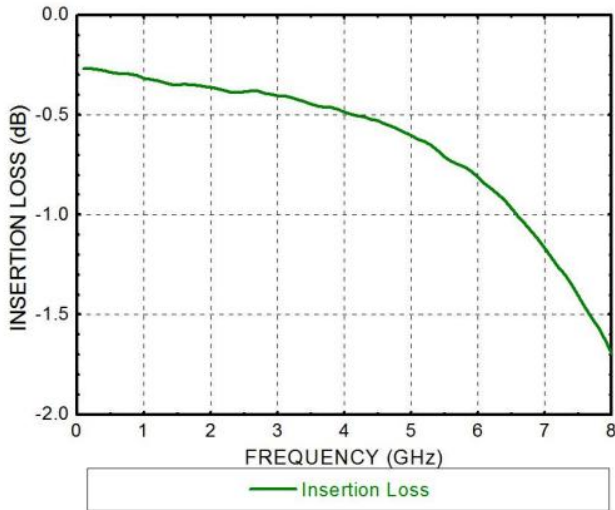

Isolation

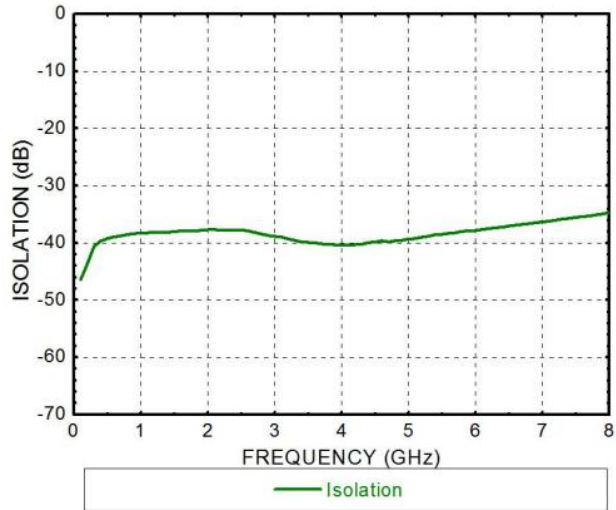

Return Loss (ON State)

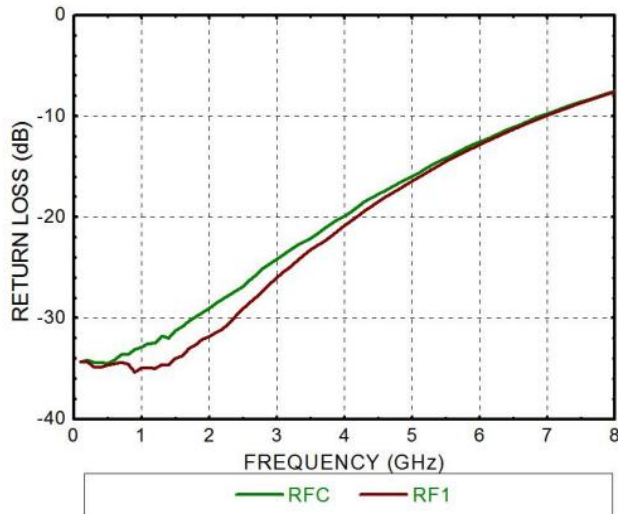

Insertion Loss Compression vs Input Power (Normalized)

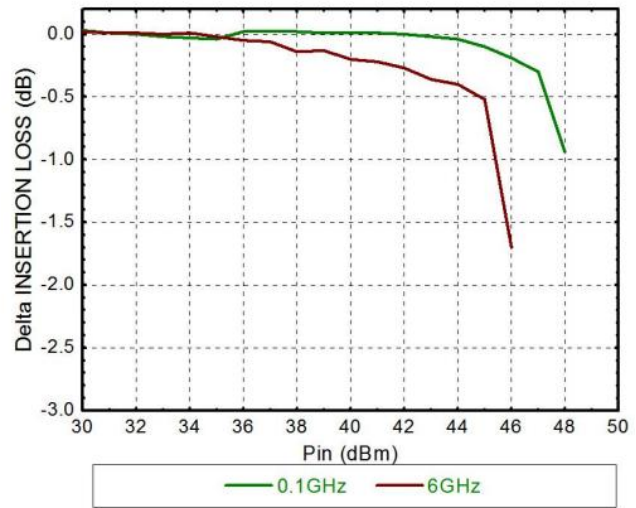



Outline Drawing:

All Dimensions in mm

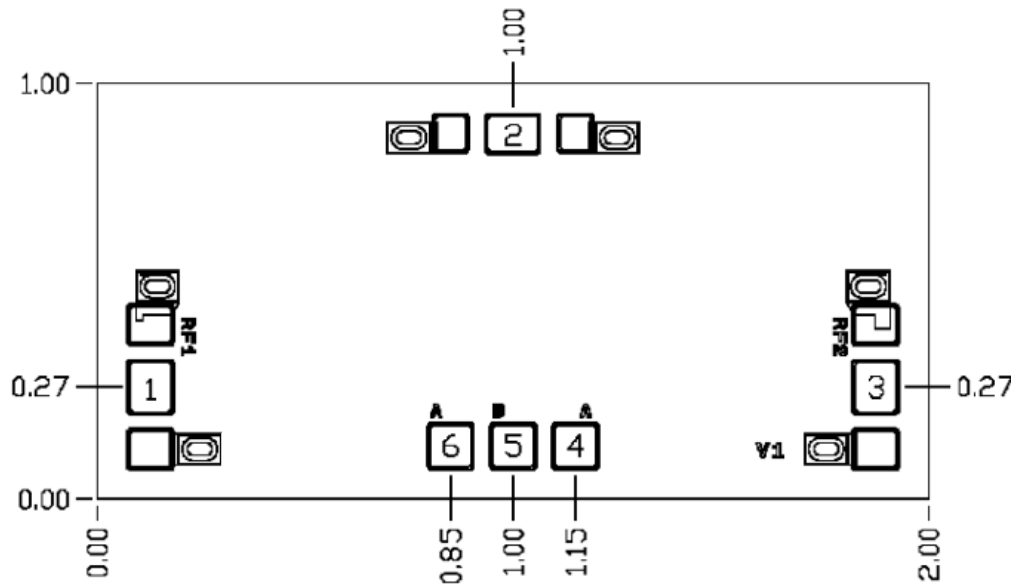

Pad Description

PAD	Function	Description
2	RFC	The pad is DC coupling and matched to 50Ω, and blocking capacitor is required externally.
1,3	RF1,RF2	The pad is DC coupling and matched to 50Ω, and blocking capacitor is required externally.
4,6	VA	When A=+28V, B=0V, then RF1 is "ON" state, RF2 is "OFF" state; When A=0V, B=28V, then RF1 is "OFF" state, RF2 is "ON" state.
5	VB	
Die Bottom	GND	Die bottom must be connected to RF/DC ground.

True Table

Function	A	B
RFC-RF1	+28V	0V
RFC-RF2	0V	+28V



Assembly Drawing

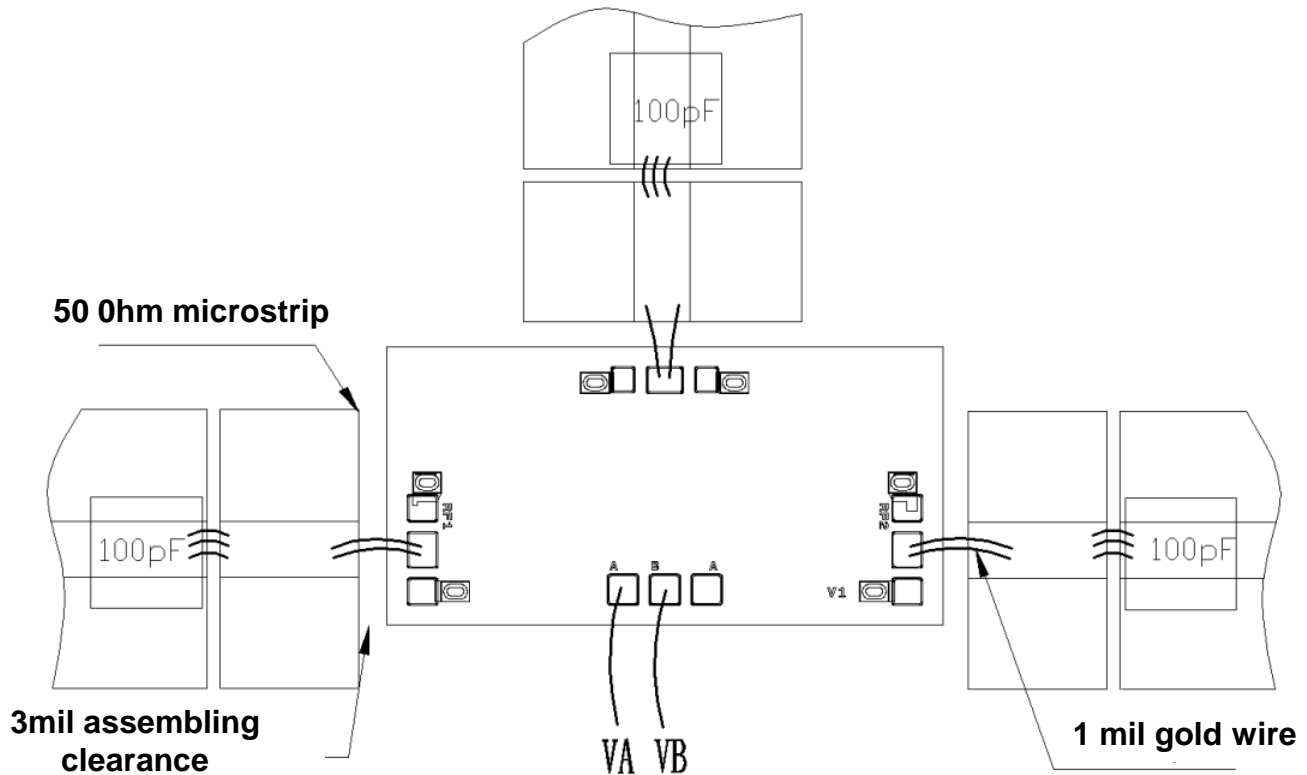

Notes:

1. Die thickness: 100um
2. Typical bond pad is 100*100 μm^2
3. Bond pad metalization: Gold
4. Backside metalization: Gold
5. Backside of the die (GND)
6. No connection required for unlabeled bond pads

Maximum Ratings:

1. Control voltage: +40V
2. Control current: 2mA
3. Maximum input power @0.1GHz: 48dBm
(Continuous wave, 50 Ω , withstands for 20 minutes)
4. Maximum input power @6GHz: 45dBm
(Continuous wave, 50 Ω , withstands for 20 minutes)
5. Storage temperature: -65°C to +150°C
6. Operating temperature: -55°C to +85°C