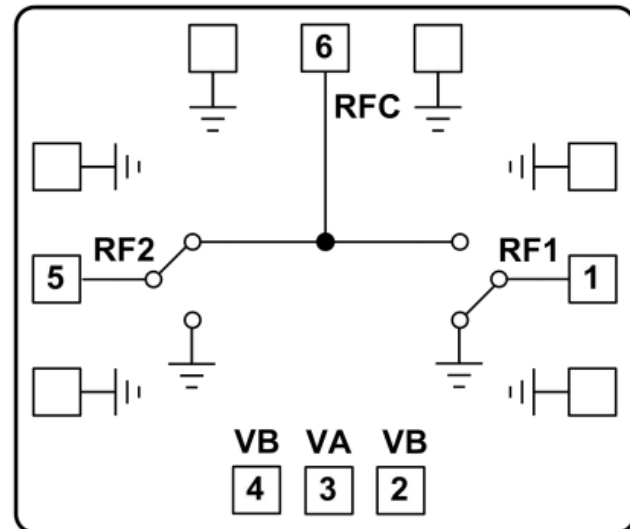

**Features**

- SPDT Reflective design
- Isolation: 33dB
- Insertion Loss: 0.8dB
- Input P-0.3: >47dBm
- Switching Time: 20ns
- Input/Output: 50 Ohm matched
- Die Size: 2.00x1.60x 0.10 mm

**Functional Block Diagram**

**Typical Applications**

- TTL compatible driver included
- Fast Switching Speed
- Low Insertion Loss and High Isolation
- Customization available upon request

**Electrical Specifications**
**TA = +25°C, VCTL=0/-40V**

Parameters	Min.	Typ.	Max.	Units
<b>Frequency</b>		<b>8-12</b>		<b>GHz</b>
<b>Insertion Loss</b>		<b>0.8</b>		<b>dB</b>
<b>On-state Return Loss(RFC)</b>		<b>18</b>		<b>dB</b>
<b>On-state Return Loss(RF1/RF2)</b>		<b>23</b>		<b>dB</b>
<b>Off-state Return Loss</b>		<b>2</b>		<b>dB</b>
<b>Off-state Isolation</b>		<b>33</b>		<b>dB</b>
<b>Input power 0.3dB Compression</b>	<b>47</b>			<b>dBm</b>
<b>Switching Time</b>		<b>20</b>		<b>ns</b>



### Insertion Loss

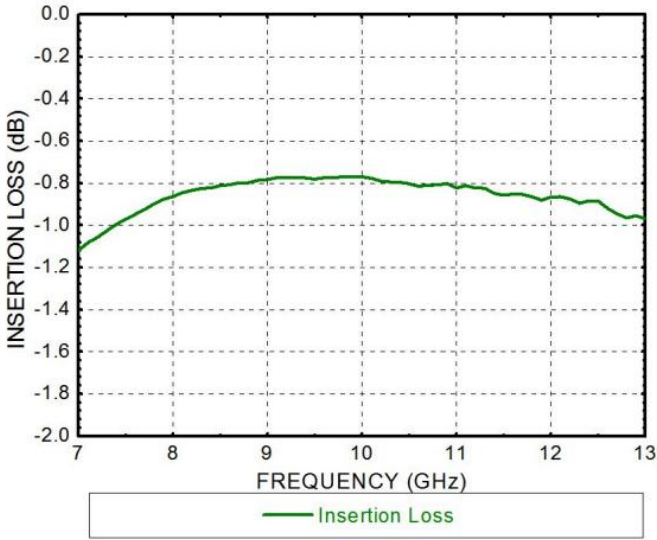

### Isolation

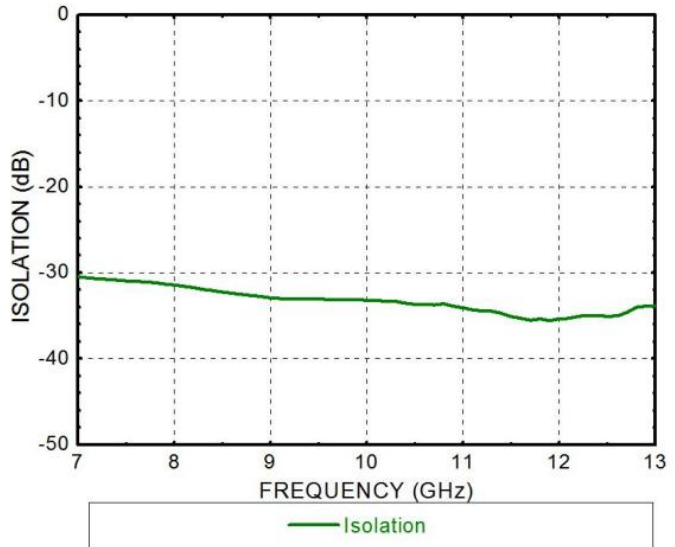

### Return Loss (ON State)

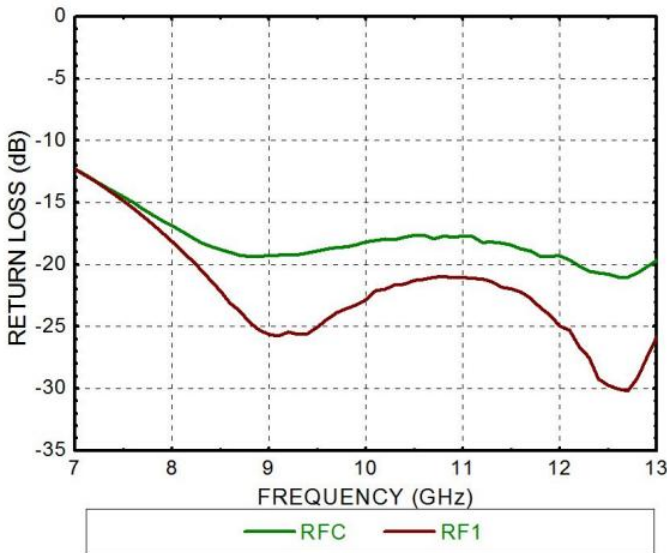

### Insertion Loss Compression vs Input Power (Normalized)

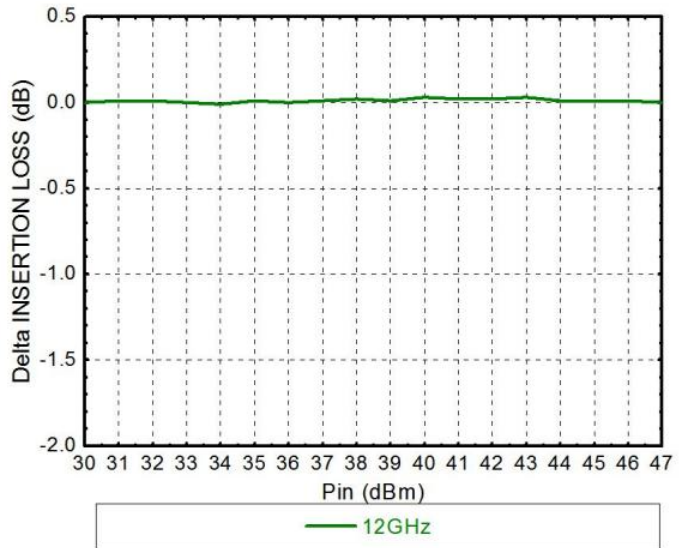



**Outline Drawing:**  
All Dimensions in mm

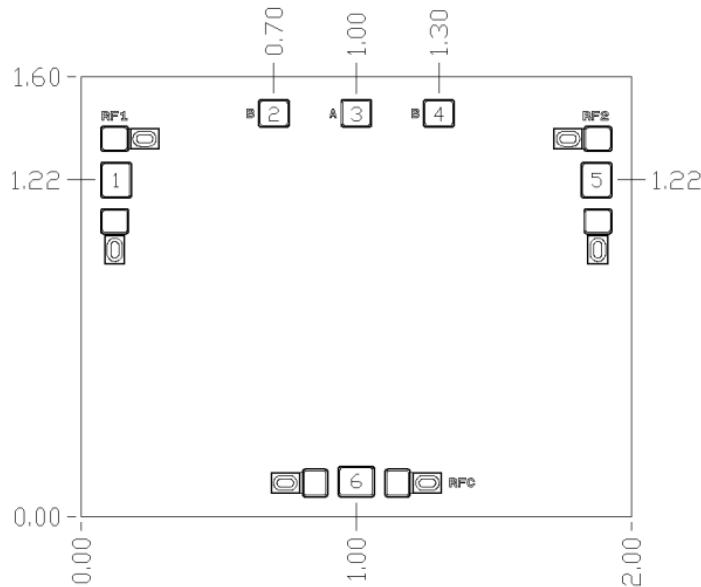

**Pad Description**

PAD	Function	Description
6	RFC	The pad is DC coupling and matched to 50Ω. If RF voltage is not 0V, then blocking capacitor is required externally.
1,5	RF1,RF2	The pad is DC coupling and matched to 50Ω. If RF voltage is not 0V, then blocking capacitor is required externally.
3	VA	When A=-40V, B=0V, then RF1 is "ON" state, RF2 is "OFF" state; When A=0V, B=-40V, then RF1 is "OFF" state, RF2 is "ON" state.
2,4	VB	
Die Bottom	GND	Die bottom must be connected to RF/DC ground.

**True Table**

Function	A	B
RFC-RF1	-40V	0V
RFC-RF2	0V	-40V



### Assembly Drawing

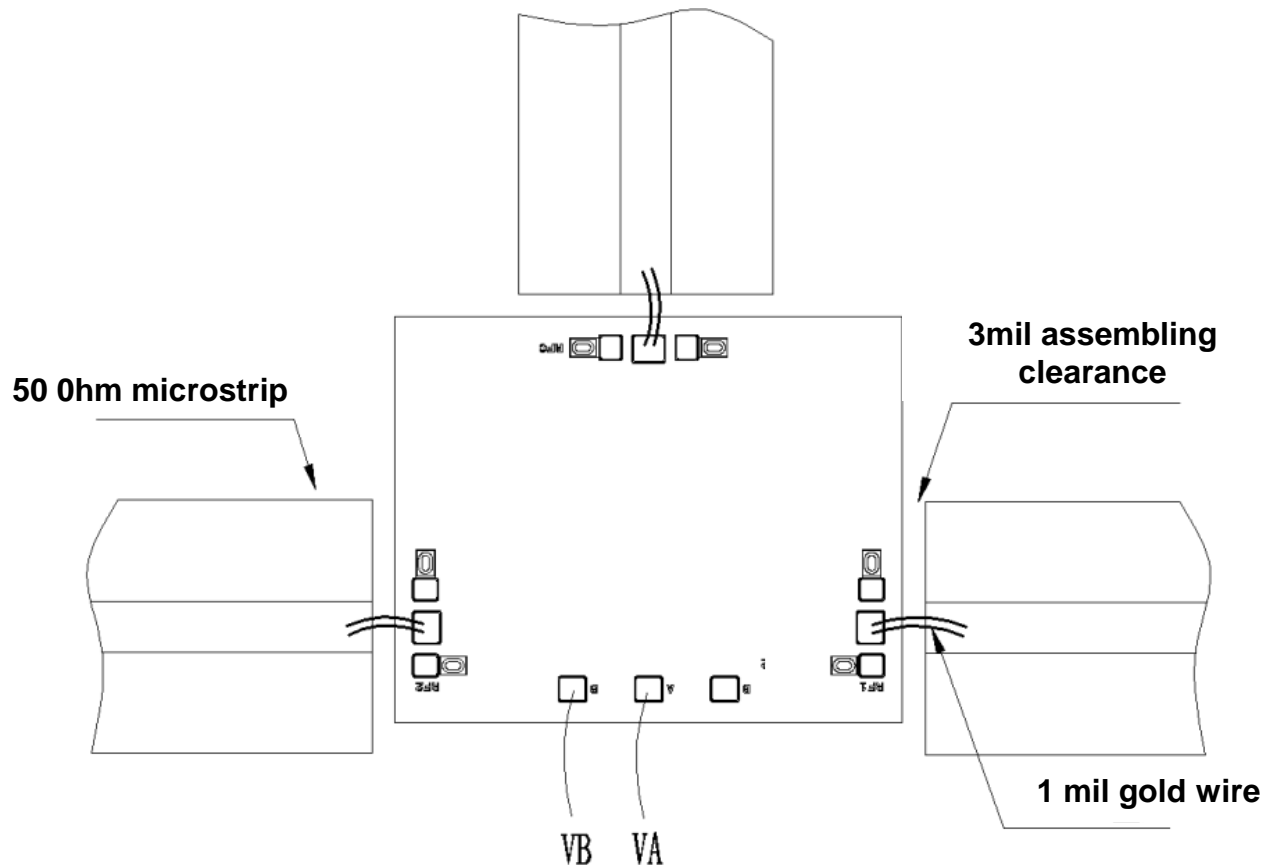

#### Notes:

1. Die thickness: 100um
2. Typical bond pad is 100\*100  $\mu\text{m}^2$
3. Bond pad metalization: Gold
4. Backside metalization: Gold
5. Backside of the die (GND)
6. No connection required for unlabeled bond pads

#### Maximum Ratings:

1. Control voltage: -50V
2. Control current: 2mA
3. Maximum input power: TBD  
(Continuous wave, 50 $\Omega$ , withstands for 20 minutes)
4. Storage temperature: -65°C to +150°C
5. Operating temperature: -55°C to +85°C